



Benzene Monitor

Instrument User Manual V1.1





THIS PAGE IS LEFT INTENTIONALLY BLANK

Thank you for purchasing your ION Science instrument.

Register your instrument online for extended warranty

The standard warranty of your Benzene Monitor can be extended up to two years.

To receive your extended warranty, you must register your instrument online within one month of purchase (terms and conditions apply).

Visit www.ionscience.com



Content

<i>EU Declaration of conformity</i>	7
<i>Statements</i>	8
Validity of this Manual	8
Responsibility for Correct Use.....	8
Quality Assurance	8
Disposal	8
Legal Notice	8
Warranty	8
Service.....	9
<i>Introduction to benzene monitor</i>	10
<i>Technical Specification</i>	11
<i>Un-Packing</i>	12
<i>Benzene monitor and Accessories Kit</i>	12
<i>Benzene monitor Detector Module and Accessories Kit</i>	13
<i>System Description</i>	14
The Gas Detector.....	14
Pneumatic Connections	14
Pneumatics	15
Running and Sampling Flow.....	15
Heaters	16
Outputs and Communications	17
<i>RS485 Modbus Interface</i>	18
Function Codes.....	18
Bytes and Words	18
Input Registers Address Map	18
Holding Registers Address Map.....	20
System Files	22
Modbus Error Flags	22
<i>Installation Requirements</i>	22
Location Requirements.....	22
Power Requirements.....	23
Cable and Gland Requirements.....	23
<i>RS485 Connections</i>	24
<i>Installation</i>	24
Preparation for Installation	24

Dimensions for Installation	25
To Install the Housing Module	25
After-Installation Test.....	26
Electrical Connections.....	26
Terminal Block-2 (Communications).....	27
Circuit diagrams for 4-20 mA monitoring.....	28
Removal and Installation of the Detection Module.....	29
To Remove the Detection Module	29
To Install the Detection Module.....	31
Operating the benzene monitor.....	35
Switches and Display	35
Power on	35
Main screens and main menu	35
Menu Icons	36
Navigation	36
Benzene Calibration	37
Removal of the Memory Card	38
Password Lock.....	39
Lock the Calibration.....	39
Lock the STEL and LIVE Displays	41
Alarms and Relays	41
Alarm or Relay Selection.....	42
Alarm Configuration	42
Relay Configuration.....	42
Relays and 4-20mA Test.....	43
Information Pages	43
Fault Indications.....	44
Alarm Indications	45
Service Period Reminder.....	45
Benzene monitor PC Software.....	46
Minimum requirements	46
Connect the benzene monitor to the PC.....	46
Starting the Software	47
Data Connection.....	48
Settings.....	49
Data Download	50
Data View	51



Upgrade..... 54

Calibration 55

Recorded Faults 56

Alarm Set..... 58

Virtual Screen 58

Engineering..... 59

***Bump Test*..... 60**

 Use of the Test 60

 Test Procedure..... 60

***Fault Diagnostics*..... 61**

 Fault and Alarm indications 62

 Fault Conditions 62

 Abbreviations:..... 62

 Benzene monitor PC Fault Groups..... 65

***ION Science Contact Details* 66**

***Manual Log*..... 67**

EU Declaration of conformity

EU Declaration of conformity

The EU Authorised Representative of the manufacturer Ion Science limited has sole responsibility, on the date this product accompanied by this declaration is placed on the market, the product conforms to all technical and regulatory requirements of the listed directives.

Authorised Representative:	Elok – Opava, spol. s r.o, .Sádek 17, 747 75 Velké Heraltice, Czech Republic
Product:	875 Benzene Monitor Type EWF 1.1
Product description:	A fixed monitor comprising of a GC column and photo-ionisation detector, for detecting and measuring ambient concentration of Benzene with internal data logging and 4-20mA or RS485 output
Directives	2014/34/EU ATEX 2014/30/EU Electrical Equipment – Electromagnetic Compatibility (EMC)
Type of protection	 II 2 G Ex db IIB+H2 T4 Gb
Certificate Number:	CZ/FTZÚ/ExTR 14.0030X (IECEX) FTZU 14/0172X (ATEX)
Notified body:	SGS Fimko 0598 Physical-Technical Testing Institute,CZ – Notified Body Number 1026
Standards:	
EN IEC 60079-0: 2018	Electrical apparatus for explosive gas atmospheres. General requirements
EN IEC 60079-1:2014	Explosive Atmospheres - Equipment Protection by flame-proof enclosure 'd'
EN IEC 61000-6-2:2005	Electromagnetic compatibility (EMC) generic standard for immunity for industrial environments.
EN 61010-1:2010	Safety requirements for electrical equipment for measurement, control and laboratory use. General requirements.
EN IEC 61000-6-4 :2007 & A1:2011	Electromagnetic compatibility (EMC) generic standard emission standard for industrial environments.
EN 50270:2015	Electromagnetic compatibility - Electrical apparatus for the detection and measurement of combustible gases, toxic gases or oxygen. Immunity Type 2 - industrial environments.
EN 61326-1:2013	Electrical equipment for measurement, control and laboratory use - EMC requirement - Part 1: General requirements.
EN ISO/ IEC 9001: 2015	Quality Management System - Requirements
EN ISO/ IEC 80079-34:2020	Application of Quality Systems for equipment manufacture

Note: All measurements were performed with a configuration that assumes all screens are maintained and correctly bonded to a screened housing at each end. The only exception to this was the conducted emission tests which were performed on the inner DC cables. Performing the test directly on these lines gives a good indication that addition filtering would not be required on any AC/DC power supply to limit the conducted emissions contaminating the ship supply.

Name: Jiří Klein

Position: Authorised Representative

Signature:



Date: 24/03/2023

Statements

Validity of this Manual

This user manual gives information and procedures for the following firmware versions:

Benzene monitor Firmware Version : V0.2.13

Benzene monitor PC Software Version : V1.0.1.88

Responsibility for Correct Use

Ion Science Ltd accepts no responsibility for incorrect adjustments that cause harm or damage to persons or property. The users are responsible to respond appropriately to the readings and alarms given by benzene monitor.

Use the equipment in accordance with this manual, and in compliance with local safety standards. Use of external circuit breakers and/or fuse protection is recommended for safe operation in the case of rare malfunction.

Reduced performance of gas detection might not be obvious, so equipment must be inspected and maintained regularly. Ion Science recommends:

- you use a schedule of regular checks to ensure it performs within calibration limits, and
- you keep a record of calibration check data.

WARNINGS:

1. Substitution of components can result in unsafe conditions.
2. For safety, benzene monitor must only be operated and maintained by qualified personnel.
3. Read and understand this Manual fully before you install, operate or maintain benzene monitor.
4. ! DO NOT OPEN WHILE ENERGIZED !
5. ! DO NOT OPEN WHILE A HAZARDOUS ATMOSPHERE MAY BE PRESENT !
6. When performing any kind of servicing on benzene monitor, precautions must be taken to prevent damage caused by ESD (Electrostatic Discharge). Measures, including ESD wrist straps and work mats must be employed.

Quality Assurance

Benzene monitor is manufactured in a ISO9001:2015 compliant Quality management system. That ensures that the equipment is:

- designed and assembled reproducibly, from traceable components,
- calibrated to the stated standards before it leaves our factory.

Disposal

Dispose of the benzene monitor and its components in accordance with all local and national safety and environmental requirements. This includes the European WEEE (Waste Electrical and Electronic Equipment) directive. Ion Science Ltd offers a take-back service. Please contact us for more information.

Legal Notice

Whilst every attempt is made to ensure the accuracy of the information contained in this manual, Ion Science accepts no liability for errors or omissions, or any consequences deriving from the use of information contained herein. It is provided "as is" and without any representation, term, condition or warranty of any kind, either expressed or implied. To the extent permitted by law, Ion Science shall not be liable to any person or entity for any loss or damage which may arise from the use of this manual. We reserve the right at any time and without any notice to remove, amend or vary any of the content which appears herein.

Warranty

You can extend the Standard Warranty up to 2 years when you register your benzene monitor instrument via our website: ionscience.com/instrument-registration

To receive your Extended Warranty, you must register within one month of purchase (Terms and Conditions apply). You will then receive a confirmation email that your Extended Warranty Period has been activated and processed.

Full details, along with a copy of our Warranty Statement can be found by visiting: www.ionscience.com

Service

For optimal performance of the Benzene monitor, ION Science recommends performing service and maintenance at 6-month and 12-month intervals in a clean and dry installation environment.

***Full 6-month and 12-month service maintenance should be conducted by a qualified ION Science service centre/personnel.**

Please note; certain application and installation factors may require more frequent maintenance. Factors such as high dust content, water vapor, and moisture ingress can necessitate more frequent service intervals to ensure the continued accuracy and reliability of the Benzene monitor.

Contact [ION Science](#) or your local distributor if you have any questions or need guidance or assistance with scheduling maintenance.

Break down of the service maintenance kits for the Benzene monitor:

SERTN2-6 : Benzene monitor Maintenance Kit 6 Month

- LA4STL3.2 : Benzene monitor Lamp (3.2V to 3.6V) 10.6eV
- A-846941 : Electrode Stack GOLD SPOT
- A-924221 : Benzene monitor Maintenance Kit 6 Month Pre-Assembly
 - 4/EB-14 : Grip Seal Bag 150mm x 255mm
 - 1/HT-15 : Cable Tie 203mm x 2.5mm (x 2)
 - A-875417 : Hydrophobic Filter
 - A-875505 : Carbon Filter Assembly (with Connectors)
 - A-924217 : Inline Filter assembly
 - A-924218 VRV restrictor assembly

SERTN2-12 : Benzene monitor Maintenance Kit 12 Month

- LA4STL3.2 : Benzene monitor Lamp (3.2V to 3.6V) 10.6eV
- A-846941 : Electrode Stack GOLD SPOT
- A-875232 : AirSep Filter Assembly
- A-924216 : Benzene monitor Maintenance Kit 12 Month Pre-Assembly
 - 4/EB-14 : Grip Seal Bag 150mm x 255mm
 - 1/HT-15 : Cable Tie 203mm x 2.5mm (x 2)
 - A-875417 : Hydrophobic Filter
 - A-875505 : Carbon Filter Assembly (with Connectors)
 - A-924217 : Inline Filter assembly
 - A-924218 VRV restrictor assembly

Contact ION Science or your local distributor for service options in your area.

Introduction to benzene monitor

The benzene monitor certified for Zone 1 hazardous areas. It detects 0.02 - 20 ppm concentrations in ambient air, taking one sample per minute.

It monitors both the current benzene concentration and the STEL (Short-Term Exposure Limit, calculated over the previous 15 minutes).

Real-time display of the measurement is on the LCD and transmitted on a 4-20 mA channel. Historic data stored in benzene monitor can be viewed and stored externally either over the RS485 or the USB connection.

Alarms and warnings are transmitted by the 4-20 mA channel and by two relays programmable to be Normally Open or Normally Closed.

It is powered by a single power supply in the range of range of 19VDC @ 4A to 32VDC @ 2.4A.

The benzene monitor has two modules:

- The Housing Module that is installed permanently.
- The Detection Module that can be removed for servicing and calibration.

All the operational and calibration data is stored within the Detection Module. After the Detection Module has been calibrated, it will function correctly when installed in any Housing Module.

A Detection Module can be calibrated and tested off-site, then taken to the installation site and installed in place of an existing module. The removed module can then be serviced ready for installation later or in another Housing Module.

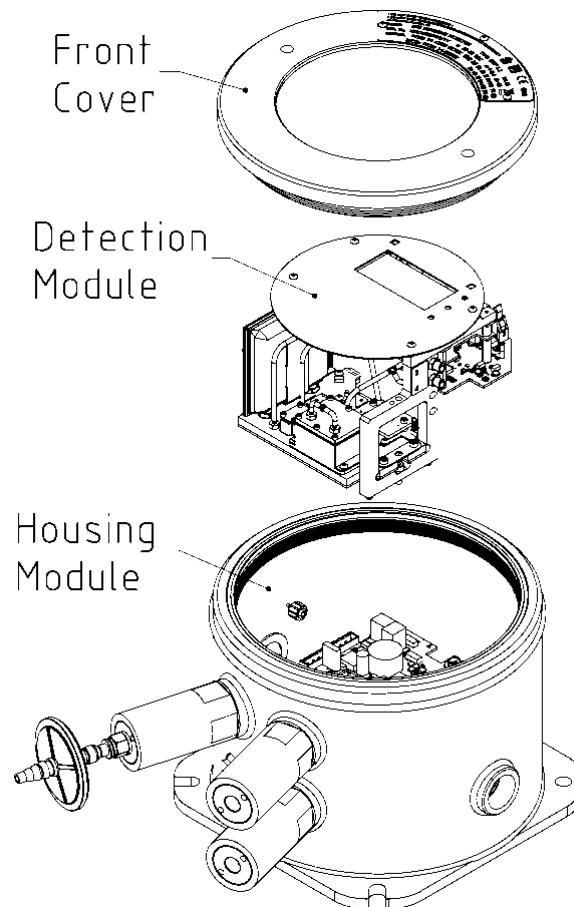

Technical Specification

Sensor type:	MiniPID T2 10.0 eV Sensor
Selectivity:	Benzene specific within typical petrochemical matrix
Detectable range:	0.02 ppm - 20 ppm
Measurement frequency:	One minute
Lower limit of detection:	0.02 ppm (20 ppb) (10 ppb resolution)
Accuracy:	± 50 ppb or ± 10 %, whichever is greater*
Temperature stability:	Internally heated
Flow rate:	Sample flow rate ≥ 100 ml/min
Display:	Graphic BW LCD 64 x 128 pixels with backlight bright LEDs for normal operation, fault and alarm Two magnetic switches for menu operation
Operating temperature:	Recommended operating range of -20 °C to 50 °C (-4 °F to 122 °F) for optimum performance**
Approvals:	4FTZU 14 ATEX 0172X Ex II 2G Ex db IIB+H2 T4 Gb Tamb. = -20 °C to +55 °C IECEX FTZU 14.0030X Ex db IIB+H2 T4 Gb Tamb. = -20 °C to +55 °C QPS LR1621-1 Ex db IIB+H2 T4 Gb AEx db IIB+H2 T4 Gb Ta=-20 °C to +55 °C
Ingress protection rating:	IP65
Humidity:	0 – 99% RH
Minimum service period:	6 months – PID lamp, electrode stack, inline filter, VRV restrictor, hydrophobic & carbon filter 12 months – PID lamp, electrode stack, inline filter, VRV restrictor, hydrophobic & carbon filter and AirSep filter
Cable entry:	Two ¼ NPT gland threads
Power requirements:	Vin (nom) 24 V DC @ 3.2 A (recommended) Vin (max) 32 V DC @ 2.4 A Vin (min) 19 V DC @ 4.0 A
Communication:	Isolated 4-20 mA output Isolated RS 485 Modbus connection via ASCII or RTU (simplex/half duplex or fully duplex) Micro USB (PC Software)
Data storage:	On board MMC, minimum of six months (2GB)
Relay output:	Two isolated outputs, voltage free, 24 V DC @ 1.25 A
Weight and dimensions	15 kg (33 lbs) 219 x 219 x 172 mm (8.6 x 8.6 x 6.8" approx.)
Gas sample line:	10 m max length, PTFE, 6 mm OD, 4mm ID

*± 10 ppb for readings ≤ 0.1 ppm

**+55 °C = ± 20% accuracy

Un-Packing

All equipment shipped by Ion Science Ltd is packed in containers with shock absorbing filling to protect them against physical damage.

Remove the contents carefully and check them against the packing list. Report discrepancies between the contents and the packing list to Ion Science Ltd. Ion Science will not be responsible for discrepancies not reported within ten days of your receipt of the shipment.

Every benzene monitor (new units and those returned from a Service Centre) must have a Certificate of Calibration before you install it.

Benzene Monitor and Accessories Kit

Part number	Description	Qty.
TN2XSXBXX-X	Benzene Monitor	Kit
A-875281	Benzene Monitor Enclosure Assembly	1
A-924206	Benzene Monitor Detector Module	1
875413	Benzene monitor Handles	2
875400	Transit Strap	1
2/SH10-16	Transit Strap Screws (M10x16)	2
A-875417	Hydrophobic Filter	1
4/PB-05	Gland Port Plug (for transportation)	2
875431	Mounting Template	1
–	Benzene Monitor Safety Notice	1
–	Benzene Monitor Responsibility of Correct Use	1
–	Calibration Certificate	1

Part number	Description	Qty.
A-875522	Benzene Monitor Accessory Kit	Kit
–	9-Way Connector	1
–	5-Way Connector	1
–	2 mm Allen Key	1
–	2.5 mm Allen Key	1
–	3 mm Allen Key	1
–	Benzene Monitor Actuation Magnet	1

Benzene Monitor Detector Module and Accessories Kit

Part number	Description	Qty.
T2SMXSXXX-X	Benzene Monitor Detector Module and Accessories Kit Comprising:	Kit
A-924206	Benzene Monitor Detector Module	1
A-924213	Benzene Monitor Facia Plate	1
A-924214	Benzene Monitor Detector Module Case Kit	1
875413	Benzene Monitor Handles	2
4/TA-06	Allen Key 2mm	1
4/TA-07	Allen Key 2.5 mm	1
4/TA-08	Allen Key 3mm	1
A-875505	Carbon Filter Assembly	1
–	Certificate of Calibration	1

Benzene Monitor Label Information: Ensure Warning Label is attached to benzene monitor.

WARNING: DO NOT OPEN WHILE ENERGIZED!

WARNING: DO NOT OPEN WHILE A HAZARDOUS ATMOSPHERE MAY BE PRESENT!



Refer to instruction manual/booklet



Separate collection for WEEE-Waste of electrical and electronic equipment



IP65 Dust-tight and protected against water jets

System Description

The Gas Detector

The benzene monitor samples the ambient air once every 60 seconds and passes the sample through a Photo-Ionisation Detector (PID).

The PID works by illuminating sample gases with high energy ultra-violet (UV) light. Benzene is one of the volatile organic compounds (VOCs) ionised by the UV photons. In a high voltage electric field, these ions create a current that can be amplified and measured to quantify the concentration of gases present. To make the measurements specific to benzene, it must be separated out from the other gasses before the PID measurement. benzene monitor incorporates the MiniPID T2, this sensor is humidity resistant and has an anti contamination design.

The sample passes through the AirSep filter which retards some gas components more than others. Under controlled conditions the filtration ensures the benzene will pass through the filter at a known and well defined time as a separated component. The benzene level is measured by analysis of the signal profile of the PID as the gasses from the AirSep filter pass through it.

For optimum performance it is important that the filter temperature and sample flow are tightly controlled. To achieve temperature stability, the AirSep filter is controlled to 50degC and the internal air temperature of the benzene monitor is controlled to a maximum of 50degC by separate heating systems.

There is no forced cooling mechanism so if the ambient temperature exceeds 55degC the measurement of benzene will be lower than the actual concentration.

Make sure to install the benzene monitor where the ambient temperature does not rise above 55degC.

Pneumatic Connections

The benzene monitor has three flame-arrestor connectors: one inlet and one outlet for the sampled air, and one breather. The breather keeps pressure equilibrium between inside and outside of the housing.

The outlet flame-arrestor can have an exhaust tube attached, to remove the processed air away from the inlet.

Internally, there is also an inlet through the carbon filter and an outlet into the interior space.

Note: Ensure you connect the inlet and outlet tubing to the right ports on the module.

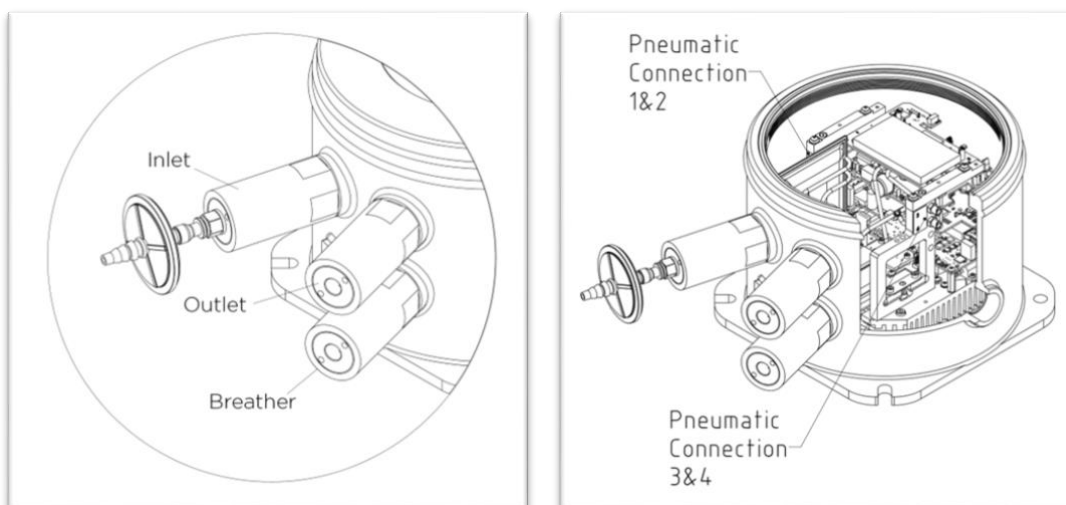

Pneumatics

In running flow:

- Pump P2 (outer loop) runs for 40 seconds out of every one minute cycle. The pump is stopped for twenty seconds to allow accurate sampling by Valve V1. When the Valve V1 is in its normal "running" position, the air bypasses the Photo-Ionization Detector (PID).
- Pump P1 (inner loop) keeps a constant flow of clean air from the internal (carbon) filter through the PID. Pump P1 (inner loop) outlet is inside the housing. Thus the clean air recycles through the internal (carbon) filter.

In sampling flow:

- At 60 second intervals, Valve V1 moves to its "sampling" position for 1 second.
- Pump P1 (inner loop) then draws a sample of air from the Pump P2 (outer loop) flow. Through the AirSep filter and the PID.
- Analysis of the PID signal profile gives the benzene concentration.

Pump P1 (inner loop) flow is approximately 6 mL per min.

Pump P2 (outer loop) flow is ≥ 100 mL per min.

The pressure sensors monitor the correct functioning of the pneumatic systems.

The external (hydrophobic) filter removes particles and moisture from the inlet Flow. Every three hours by the clock (00:00, 03:00, 06:00...) the benzene monitor will stop to measure the ambient pressure conditions to correctly adjust for flow control. Important note: bump testing is inadvisable at these times as external pressure sources will affect the pressure calibration process

Running and Sampling Flow

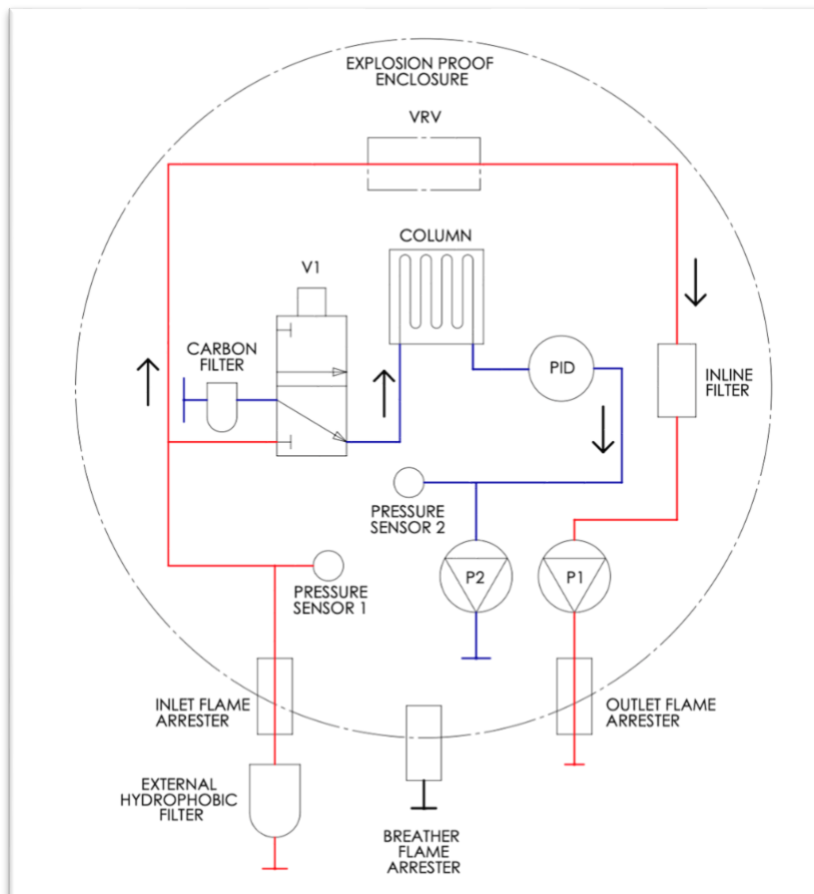

Heaters

The benzene monitor has two heating systems, one regulates the internal temperature, the other regulates the temperature of the AirSep filter.

Internal temperature regulation is maintained by a set of four resistors in the base of the Housing Module.

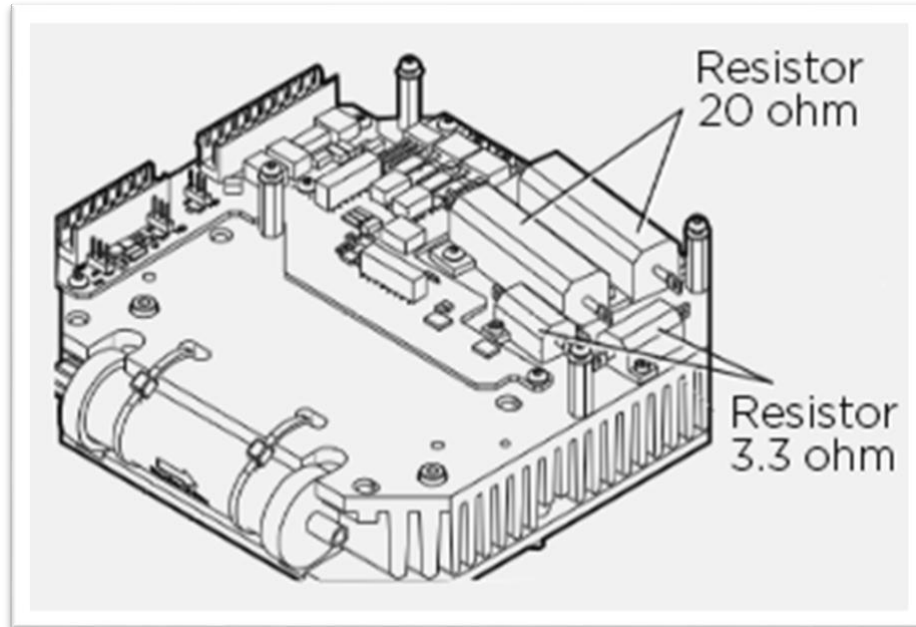

AirSep filter temperature regulation is by two, 12V 2.5W, heater-mats within an insulated jacket in the Detection Module.

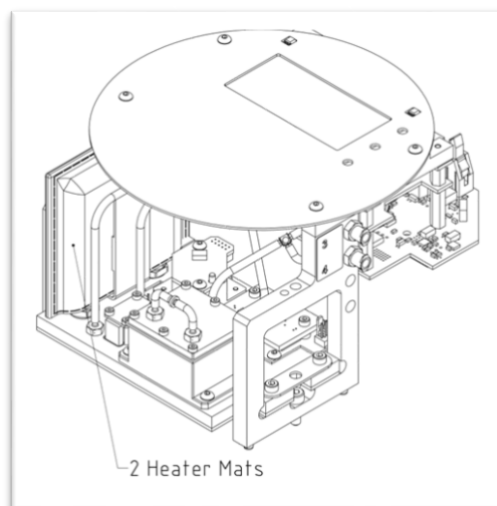

Outputs and Communications

Benzene monitor has five communication outputs:

- The on-board LCD and LEDs on the faceplate.
- 4-20mA Current Loop.
- RS485 Modbus (simplex/half-duplex or fully-duplex),
- USB (Accessible on the Detector Module).
- Two programmable relays.

Benzene monitors, in real-time, the current (Live) and the Short-Term Exposure Limit (STEL) benzene concentration. The STEL is calculated over the previous 15 minutes.

This real-time information is displayed on the LCD and transmitted on the 4-20mA and RS485 channels.

You can program two alarms to operate at a chosen concentration of benzene and/or a chosen STEL limit. The alarms will display a message on the LCD and LEDs; energize the relays; and transmit a signal on the 4-20mA channel.

The alarms and relays are individually programmable to the settings required by the site policy. You can choose either alarm to energize either relay. The default settings would be:

- Alarm 1: 5.0ppm live
- Alarm 2: 0.5ppm STEL
- Relay 1: Alarm 1, N/O
- Relay 2: Alarm 2, N/O

Both relays can be programmed to be Normally Open or Normally Closed. They can switch 24VDC at 1.5A maximum load. When the benzene monitor is not powered the default state of relay 1 is N/C, the default state of relay 2 is N/O

Data is stored internally for a minimum of two years and can be downloaded with benzene monitor PC software via USB or RS485 for analysis and archive storage.

You can configure the RS485 connection for half-duplex, 2-wire. Refer to Installation, [Terminal Block-2](#).

The 4-20mA output fault indications are given by discrete current signals between 2.0 and 3.5mA. Refer to the table in Fault Diagnostics, [Fault Conditions](#).

RS485 Modbus Interface

The benzene monitor Modbus interface uses either Serial ASCII format Modbus or RTU, at:

- 38400 baud 8 data bits, no parity, 2 stop bits.

Function Codes

Benzene monitor supports these function codes:

- 0x03 – Read Holding Registers
- 0x04 – Read Input Registers
- 0x10 – Write Multiple Registers

The address map for Read Holding Registers and Write Multiple Registers is the same – but not all addresses are writeable.

Bytes and Words

Modbus registers are generally 16 bits in length. For example if you send the command to Read Input Registers with a register quantity of 1 you will receive 2 bytes (1 word) of data. In the tables of addresses, we specify the length in bytes. This is the number of bytes of data associated with the read/write at that address.

Thus your Modbus request will be for half that number of registers.

Input Registers Address Map

Use the function code 0x04 to Read Input Registers in the address range given in the table. If you read more than the number of bytes indicated for the length at each address, any bytes beyond the length are undefined.

For example, if you read 32 bytes at address 1000, only the first 16 bytes returned are valid.

Address (hex)	Data Length (bytes)	Content																																
0	60	Returns block of 15 integers for latest result <table border="0" style="margin-left: 20px;"> <tr> <td>Integer</td> <td>Meaning</td> </tr> <tr> <td>1</td> <td>Benzene value in ppm x 10</td> </tr> <tr> <td>2</td> <td>Sensor temperature in degC x 100</td> </tr> <tr> <td>3</td> <td>Ambient temperature in degC x 10</td> </tr> <tr> <td>4</td> <td>Flow in ml/min x 100</td> </tr> <tr> <td>5</td> <td>PS1 diagnostic</td> </tr> <tr> <td>6</td> <td>PS2 diagnostic</td> </tr> <tr> <td>7</td> <td>PS3 diagnostic</td> </tr> <tr> <td>8</td> <td>Slope diagnostic</td> </tr> <tr> <td>9</td> <td>Flags</td> </tr> <tr> <td>10</td> <td>Sensor fence signal</td> </tr> <tr> <td>11</td> <td>Raw signal</td> </tr> <tr> <td>12</td> <td>STEL value</td> </tr> <tr> <td>13</td> <td>Pump drive signal</td> </tr> <tr> <td>14</td> <td>Pump drive volts</td> </tr> <tr> <td>15</td> <td>Fault record</td> </tr> </table>	Integer	Meaning	1	Benzene value in ppm x 10	2	Sensor temperature in degC x 100	3	Ambient temperature in degC x 10	4	Flow in ml/min x 100	5	PS1 diagnostic	6	PS2 diagnostic	7	PS3 diagnostic	8	Slope diagnostic	9	Flags	10	Sensor fence signal	11	Raw signal	12	STEL value	13	Pump drive signal	14	Pump drive volts	15	Fault record
Integer	Meaning																																	
1	Benzene value in ppm x 10																																	
2	Sensor temperature in degC x 100																																	
3	Ambient temperature in degC x 10																																	
4	Flow in ml/min x 100																																	
5	PS1 diagnostic																																	
6	PS2 diagnostic																																	
7	PS3 diagnostic																																	
8	Slope diagnostic																																	
9	Flags																																	
10	Sensor fence signal																																	
11	Raw signal																																	
12	STEL value																																	
13	Pump drive signal																																	
14	Pump drive volts																																	
15	Fault record																																	

80	24	<p>Returns block of data indicating the state of the sensor temperature controller. Six 32-bit integers are returned. e.g.</p> <pre>00000000 84 13 00 00 22 02 00 00 AD 08 00 00 A0 0F 00 00 „...“..... 00000010 01 00 00 00 01 00 00 00</pre> <p>These can be decoded as follows: 84 12 00 00 = 0x00001284 = 4740</p> <p>The values have the following meaning</p> <table border="0"> <thead> <tr> <th>Integer</th> <th>Meaning</th> </tr> </thead> <tbody> <tr> <td>1</td> <td>Temperature in degrees Celsius x 100</td> </tr> <tr> <td>2</td> <td>Ambient temperature in degC x 16</td> </tr> <tr> <td>3</td> <td>Heater drive power in % x 100</td> </tr> <tr> <td>4</td> <td>Heater driver voltage</td> </tr> <tr> <td>5</td> <td>1 if required temperature has been reached</td> </tr> <tr> <td>6</td> <td>Time in seconds taken to reach target from switch on</td> </tr> </tbody> </table>	Integer	Meaning	1	Temperature in degrees Celsius x 100	2	Ambient temperature in degC x 16	3	Heater drive power in % x 100	4	Heater driver voltage	5	1 if required temperature has been reached	6	Time in seconds taken to reach target from switch on
Integer	Meaning															
1	Temperature in degrees Celsius x 100															
2	Ambient temperature in degC x 16															
3	Heater drive power in % x 100															
4	Heater driver voltage															
5	1 if required temperature has been reached															
6	Time in seconds taken to reach target from switch on															
100	24	<p>Returns block of data indicating state of background temperature controller. Six 32-bit integers are returned. e.g.</p> <pre>00000000 FC 44 00 00 21 02 00 00 00 00 00 00 01 00 00 00 üD·!..... 00000010 EF 00 00 00 02 00 00 00</pre> <table border="0"> <thead> <tr> <th>Integer</th> <th>Meaning</th> </tr> </thead> <tbody> <tr> <td>1</td> <td>Heater Temperature in degC x 100</td> </tr> <tr> <td>2</td> <td>Ambient temperature in degC x 16</td> </tr> <tr> <td>3</td> <td>Heater drive power in % x 100</td> </tr> <tr> <td>4</td> <td>Heater driver voltage</td> </tr> <tr> <td>5</td> <td>Power supply level x 10</td> </tr> <tr> <td>6</td> <td>Heater level</td> </tr> </tbody> </table>	Integer	Meaning	1	Heater Temperature in degC x 100	2	Ambient temperature in degC x 16	3	Heater drive power in % x 100	4	Heater driver voltage	5	Power supply level x 10	6	Heater level
Integer	Meaning															
1	Heater Temperature in degC x 100															
2	Ambient temperature in degC x 16															
3	Heater drive power in % x 100															
4	Heater driver voltage															
5	Power supply level x 10															
6	Heater level															
1000	16	<p>Unique ID of benzene monitor – a string of 16 ASCII characters unique to each benzene monitor</p>														
1100	32	<p>Firmware versions of benzene monitor and Flow Controller. Two null terminated strings are returned. e.g.</p> <pre>00000000 56 30 2E 31 2E 33 33 00 56 30 2E 31 2E 31 31 00 V0.1.33-V0.1.11 00000010 00 00 00 00 00 00 00 00 00 00 00 00 00 00 00</pre>														
1200	36	<p>Returns a block of data indicating the state of the flow. This block contains 9 32-bit integers. e.g.</p> <pre>00000000 21 03 00 00 DA 0D 00 00 20 2F 00 00 88 00 00 00 !...Û... /^... 00000010 01 00 00 00 00 00 00 00</pre> <p>These can be decoded as follows: 21 03 00 00 = 0x00000321 = 801</p> <p>The values have the following meaning:</p> <table border="0"> <thead> <tr> <th>Integer</th> <th>Meaning</th> </tr> </thead> <tbody> <tr> <td>1</td> <td>Current flow x 100</td> </tr> <tr> <td>2</td> <td>Flow Differential pressure sensor reading</td> </tr> <tr> <td>3</td> <td>Absolute pressure sensor reading</td> </tr> <tr> <td>4</td> <td>Pump power output</td> </tr> </tbody> </table>	Integer	Meaning	1	Current flow x 100	2	Flow Differential pressure sensor reading	3	Absolute pressure sensor reading	4	Pump power output				
Integer	Meaning															
1	Current flow x 100															
2	Flow Differential pressure sensor reading															
3	Absolute pressure sensor reading															
4	Pump power output															

		<p>5 1 if pump power OK, 0 if pump power problem</p> <p>6 1 if outer loop pump running, 0 if outer loop pump not running</p> <p>7 Pump drive output voltage</p> <p>8 Absolute pressure when pump not running</p> <p>9 Valve state</p>
1300	12	<p>Returns information on the internal memory storage. Three 32-bit integers are returned.</p> <p>Integer Meaning</p> <p>1 Number of free clusters.</p> <p>2 Total available clusters</p> <p>3 Reserved clusters.</p>
1400	96	<p>Returns an array of 27 32-bit integers indicating internal fault state of benzene monitor. If there are no faults all values are zero.</p>
1500	20	<p>Returns five 32-bit integers indicating state of the lamp sensor.</p> <p>Integer Meaning</p> <p>1 Last signal reading in μV</p> <p>2 1 is lamp is on, 0 if not</p> <p>3 0 if lamp drive is off, non-zero if lamp drive is on</p> <p>4 Lamp sensor signal when lamp off, in μV</p> <p>5 Last Lamp sensor signal reading in μV</p>
1600	6	<p>Returns three 16-bit values containing diagnostic data for pressure sensor</p>

Holding Registers Address Map

Read Holding Registers – use function code 0x03.

Write Holding Registers – use function code 0x01 (Write Multiple Registers).

If you read or write more than the number of bytes specified for the length at each address, any bytes beyond the length are undefined.

Benzene monitor can malfunction if you write more data than the specified length.

For example if you read 32 bytes at address 1000, only the first 16 bytes returned are valid.

Address (hex)	Data Length (bytes)	Content
1100	32	<p>ASCII name allocated to the benzene monitor. This may be written or read. e.g</p> <p>00000000 53 65 72 76 69 63 65 20 54 69 74 61 6E 00 00 00 Service benzene monitor ... 00000010 00 00 00 00 00 00 00 00 00 00 00 00 00 00 00 00</p>
1200	32	<p>Internal real time clock. This may be written or read. e.g.</p> <p>00000000 DF 07 00 00 02 00 00 00 0A 00 00 00 10 00 00 00 8..... 00000010 11 00 00 00 29 00 00 00 02 00 00 00 00 00 00 00)</p>

		<p>This is decoded as 8 32-bit numbers. The last two integers are not used when writing.</p> <table border="1"> <thead> <tr> <th>Integer</th> <th>Meaning</th> </tr> </thead> <tbody> <tr><td>1</td><td>Year</td></tr> <tr><td>2</td><td>Month</td></tr> <tr><td>3</td><td>Day</td></tr> <tr><td>4</td><td>Hour</td></tr> <tr><td>5</td><td>Minute</td></tr> <tr><td>6</td><td>Second</td></tr> <tr><td>7</td><td>Day of week</td></tr> <tr><td>8</td><td>Day of year</td></tr> </tbody> </table>	Integer	Meaning	1	Year	2	Month	3	Day	4	Hour	5	Minute	6	Second	7	Day of week	8	Day of year
Integer	Meaning																			
1	Year																			
2	Month																			
3	Day																			
4	Hour																			
5	Minute																			
6	Second																			
7	Day of week																			
8	Day of year																			
1300		Used during code upgrade. For ISL use only. Reading or Writing to this address may require you to send the benzene monitor to a Service Center.																		
1400		Used during upgrade of flow controller. For ISL use only. Reading or Writing to this address may require you to send the benzene monitor to a Service Center.																		
1500	4	Override control of measuring sequence. For ISL use only.																		
1600	4	Override control of pump. For ISL use only.																		
1604	4	Override control of by-pass pump. For ISL use only.																		
1608	4	Override control of sample valve. For ISL use only.																		
1700	28	<p>Read latest result data.</p> <p>A block of 7 32-bit integers is returned</p> <table border="1"> <thead> <tr> <th>Integer</th> <th>Meaning</th> </tr> </thead> <tbody> <tr><td>1</td><td>Benzene value in ppm x 10</td></tr> <tr><td>2</td><td>Results Flags</td></tr> <tr><td>3</td><td>Flag indicating start of measurement cycle</td></tr> <tr><td>4</td><td>Diagnostic Step in measurement cycle</td></tr> <tr><td>5</td><td>Last sensor reading</td></tr> <tr><td>6</td><td>Stel result in ppm x 10</td></tr> <tr><td>7</td><td>Last fault</td></tr> </tbody> </table> <p>Writing to any space in this address range will clear flag indicating start of measurement cycle (integer 3).</p>	Integer	Meaning	1	Benzene value in ppm x 10	2	Results Flags	3	Flag indicating start of measurement cycle	4	Diagnostic Step in measurement cycle	5	Last sensor reading	6	Stel result in ppm x 10	7	Last fault		
Integer	Meaning																			
1	Benzene value in ppm x 10																			
2	Results Flags																			
3	Flag indicating start of measurement cycle																			
4	Diagnostic Step in measurement cycle																			
5	Last sensor reading																			
6	Stel result in ppm x 10																			
7	Last fault																			
1800		Diagnostic, test control of 4-20mA output. For Ion Science use only.																		
F000	44	Block of data controlling file transfer to/from internal store. Write only.																		
F080	16	Block of data giving information on file transfer to/from internal store. Read only.																		
F100	128	Used to read/write data from/to files on internal store.																		

System Files

Benzene monitor stores configuration parameters in *.CFG files in the file store.

Benzene monitor can malfunction if you delete or modify these files.

Modbus Error Flags

1	Temp Error	18	Pump Fault
2	Temp Fault	19	Pump Power Fail
3	Temp Fault	20	Step Error
4	Temp Error	21	Inlet Blocked
5	Leak	22	Temp Error
6	Sensor Flow Low	23	Memory Full
7	Sensor Flow High	24	Pump Drive High
8	Outlet Blocked	25	Alarm 1
9	Tube Off	26	Alarm 2
10	Lamp Out	27	Temp Fault
11	Memory fault	28	Pump Power Fail
12	Temp Error	29	Service Required
13	PID ADC Fail	30	Pump Reset
14	Step Overrun	31	ADS1000 Fault
15	Watchdog	32	P3 Sensor Fail
16	ADC Fault	33	Abs Pres Sensor Fail
17	MMC Fault	34	Diff Pres Sensor Fail
		35	High Background

Installation Requirements

Please make sure you understand all the installation requirements before you install benzene monitor.

Location Requirements

There are many variables involved in defining the optimum location for a gas detector. Mount the benzene monitor:

- in a location where it (or its inlet probe) is most likely to detect the gas
- in an area that has good air circulation. Restricting natural air current can result in delayed detection
- on a solid, stable support, where it is accessible for servicing
- vertically, with the flame arresters underneath the housing
- not in direct sunlight or over a heat source (This can cause the benzene monitor to exceed its certified internal working temperature of 50degC)
- not in areas likely to flood.

An exhaust line can be attached to the outlet flame-arrestor to remove the processed air away from the benzene monitor.

An inlet line (inlet probe), with hydrophobic filter can be attached to the inlet flame-arrestor to detect benzene in areas remote from the benzene monitor.

These lines can be

- Maximum of 10 metres long (ION Science recommend using a tee piece before the inlet of the benzene monitor. This will prevent any back pressure in the 10 metre sample line).
- Recommended cross-section: 6mm OD x 4mm ID PTFE tube.

NOTE: Whether the gas inputs to the unit are from the area where the flame proof box is installed or whether it inputs from another source. The gas which is pumped inside the flame proof box must be from the area where the flame proof box is installed.

Power Requirements

- Nominal Voltage 24VDC @ 3.2A
- Minimum Voltage 19VDC @ 4A
- Maximum Voltage 32VDC @ 2.4A

We recommend an industrial grade power supply unit of 24VDC at 4.5A.

Power consumption depends on the heaters in the temperature control systems. Running in ambient temperatures below 5degC will use maximum power. Higher temperatures will reduce power consumption.

The 4-20mA output requires its own power supply at 24 (minimum) to 32VDC (maximum). It can share the instrument's 24 to 32VDC, 4.5A, power supply if:

- the 4-20mA output goes to the same location as the instrument power supply and
- their Grounds will be connected together.

Refer to Electrical Connections, [Terminal Block-1](#).

Cable and Gland Requirements

We recommend you use screened cables e.g., multicore cable with SWA armour, or Braid Armour to protect against EMI.

The manufacture and build of the cable glands is the responsibility of the installer. The cable glands must conform to the certification standards required for the installation site. Install blanking plugs with the appropriate certification standards to unused cable gland ports.

For general advice on selection of cable glands please visit <https://www.cmp-products.com/cable-glands/products/explosive-atmosphere/>

DC power	2 core (positive and negative) 1.5mm ²
4-20mA Comms	2 core 1.5mm ² max
RS485 half-duplex	3 cores (including ground) 1.5mm ² max
Relays (2 Outputs)	4 cores 1.5mm ² max
Cable Gland	¾" NPT - Explosive Atmosphere Certified
Blanking Plug	¾" NPT - Explosive Atmosphere Certified

RS485 Connections

You can use benzene monitor for half-duplex, 2-wire communication. You can also configure it to use a built-in 120R termination resistor. Pin references are to Terminal Block-2 (Refer to Installation, [Terminal Block-2](#))

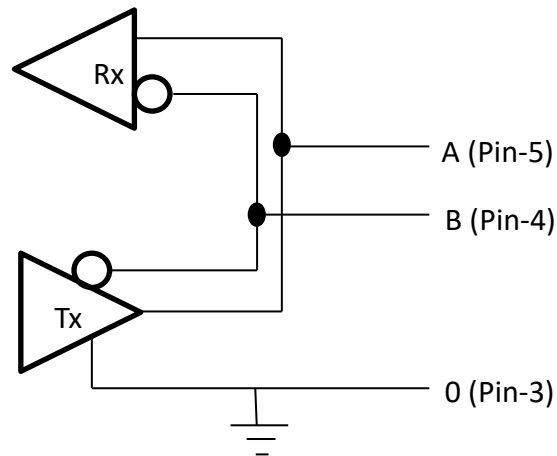

To connect a 120R termination resistor across 'A' and 'B': connect a jumper on L1 between the middle pin and 120R pin. (Refer to Note 1 of [Terminal Block-2](#), Installation).

This enables 2-wire communications and a 3rd wire ('0') as a Ground.

- 'A' is connected to 'Y'
- 'B' is connected to 'Z'
- '0' is Ground

Installation

Preparation for Installation

Before you install the benzene monitor, refer to the:

- Location requirements
- Power requirements
- Cable & gland requirements
- Dimensions for installation (See below)

Dimensions for Installation

All dimensions in mm.

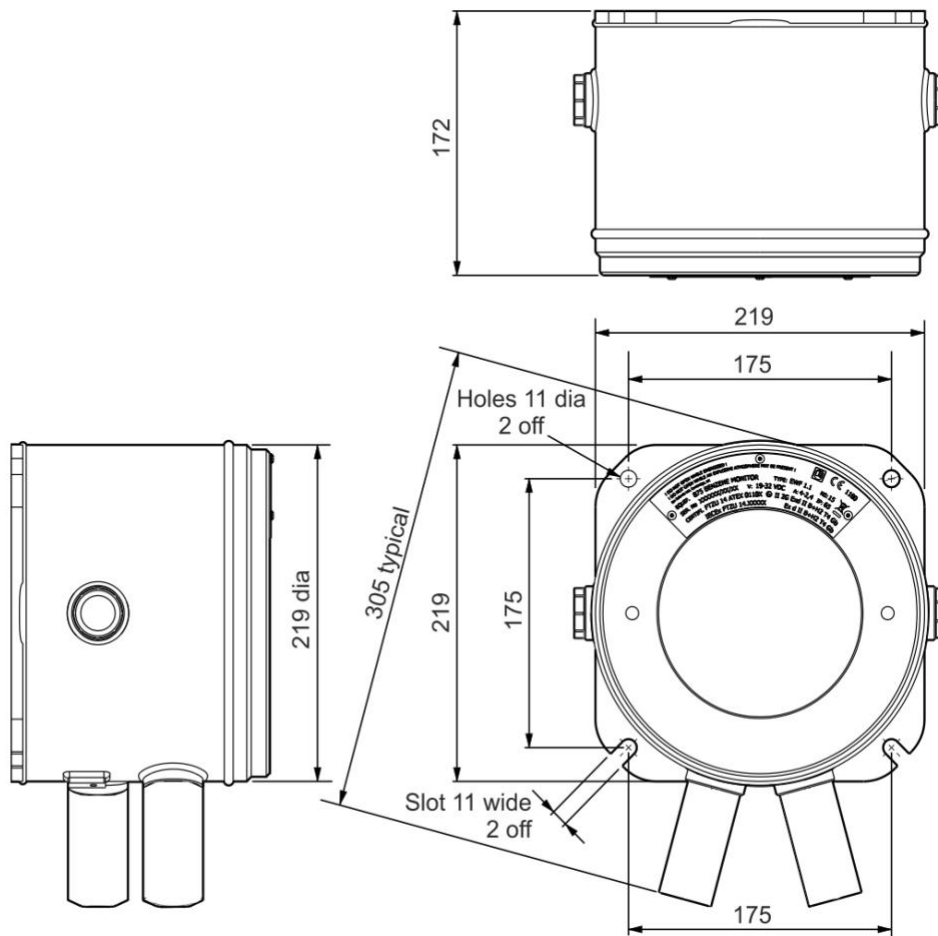

To Install the Housing Module

Use M10 screws to install the benzene monitor as a complete unit (housing and detection modules together) on a solid, stable support.

After you install the benzene monitor, remove the detection module to get access to the terminal blocks. Refer to removal and installation of the detection module.

Install the cable glands. Feed the cables through the glands and make the connection to the terminal blocks as you require. Refer to the electrical connections.

Seal the cable in the cable glands.

Install the detection module.

Connect / switch on the power supply.

Connect a PC / laptop to the USB port and use benzene monitor PC to set the date and time. Alternatively, use the RS485 connection and benzene monitor PC to set the time and date. Please ensure the date and time is set before the unit is sent to site as without external power, benzene monitor can only store the current date and time for a maximum of 12 hours.

After-Installation Test

Do a test of the relay and the 4-20mA systems to check for correct installation and function. Refer to [Relays and 4-20mA Test](#).

Do a "Bump Test" to verify that the sensors respond correctly to the Benzene gas. Refer to Bump test. For an accurate bump test the benzene monitor needs to heat up and thermally stabilise. This can take up to 90 minutes. Before this an inaccuracy of up to 15% could be seen.

A bump test does not calibrate the sensors. If the benzene monitor does not display the gas concentration given by the bottle, do a calibration to give the correct readings. Refer to

Benzene Calibration (on-board) or [Error! Reference source not found.](#) (using benzene monitor PC).

Electrical Connections

Terminal Block-1 (Power)

Pin	Label	Function
1	0V	DC Power input (Negative)
2	0V	DC Power additional input (Negative) (Connected to above Pin1 on-board) (See Note 1)
3	24	DC Power Input (Positive) +24VDC
4	24	DC Power additional input (Positive) (Connected to above Pin3 on-board) (See Note 1)
5	R1	Relay 1 output (Terminal-1)
6	R1	Relay 1 output (Terminal-2)
7	R2	Relay 2 output (Terminal-1)
8	R2	Relay 2 output (Terminal-2)
9	Is	DC Power Output (Positive) (Connected to Pin3 & 4 on-board) (See Note 2)

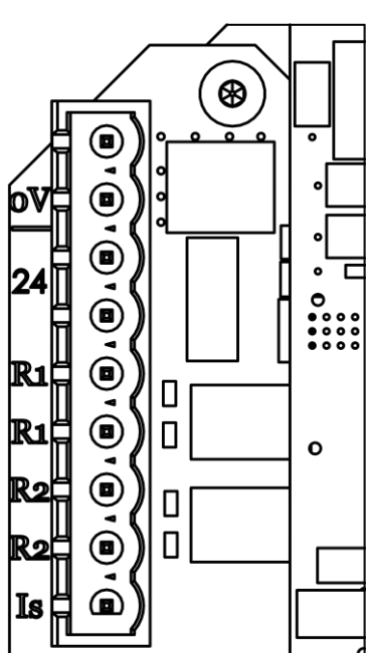

NOTES:

- Pin 2 '0V' and pin 4 '24V' on Terminal Block-1 allow two wires to share the current of the Power Supply Input.
Pin 1 and Pin 2 are connected together on-board.
Pin 3 and Pin 4 are connected together on-board.
- The 4-20mA output is NOT powered on-board. It is an isolated output that requires its own Power Supply at 24VDC (nominal) and 32VDC (maximum).

The 4-20mA output can share the instrument Power Supply if:

- the 4-20mA output goes to the same location as the instrument power supply and
- their Grounds will be connected together.

If that is so, connect a jumper from Pin 9 of Terminal Block-1 to Pin-1 of Terminal Block-2

Terminal Block-2 (Communications)

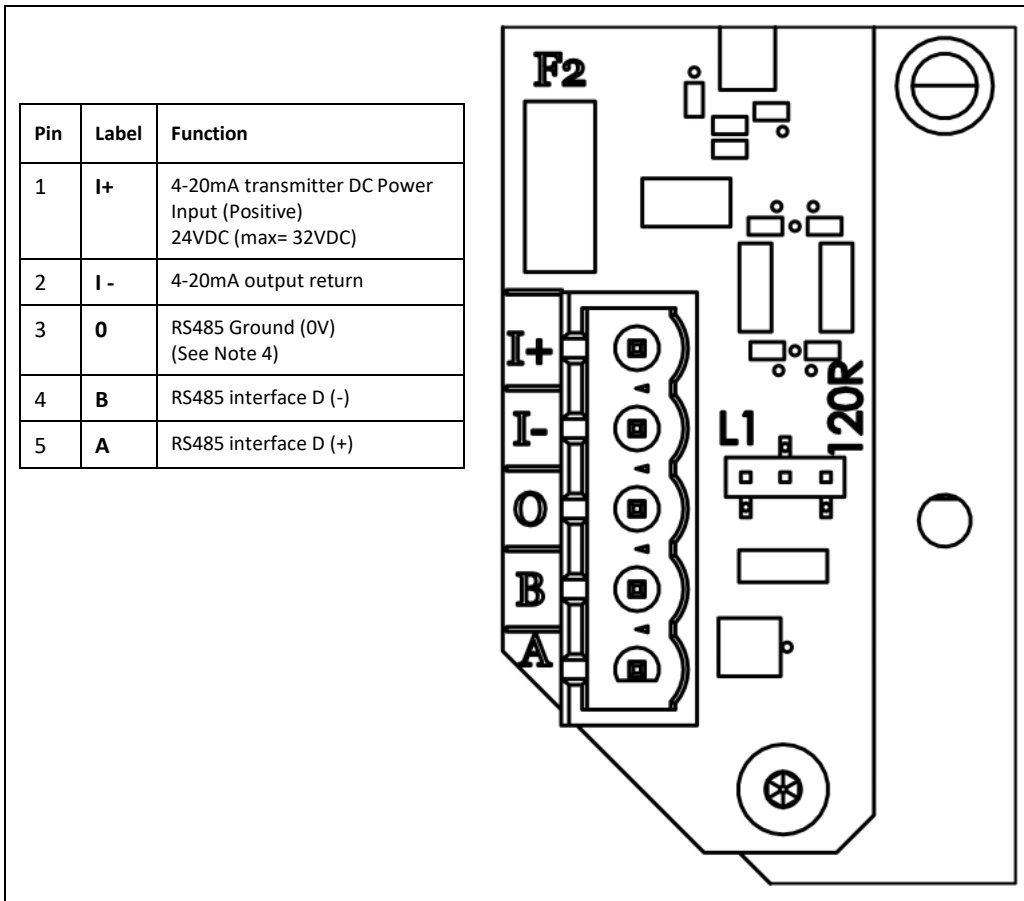

NOTES:

1. For RS485 termination resistor, put a jumper link on the L1 header between the middle pin and the pin labelled 120R. This puts a 120R termination resistor across 'A' and 'B' of Terminal Block-2 (See RS485 Connections diagram for more details). To disconnect the resistor remove the jumper completely.
2. The 4-20mA output has an inline fuse, for protection against accidental short circuit, see F2 on the above diagram.

Circuit diagrams for 4-20 mA monitoring

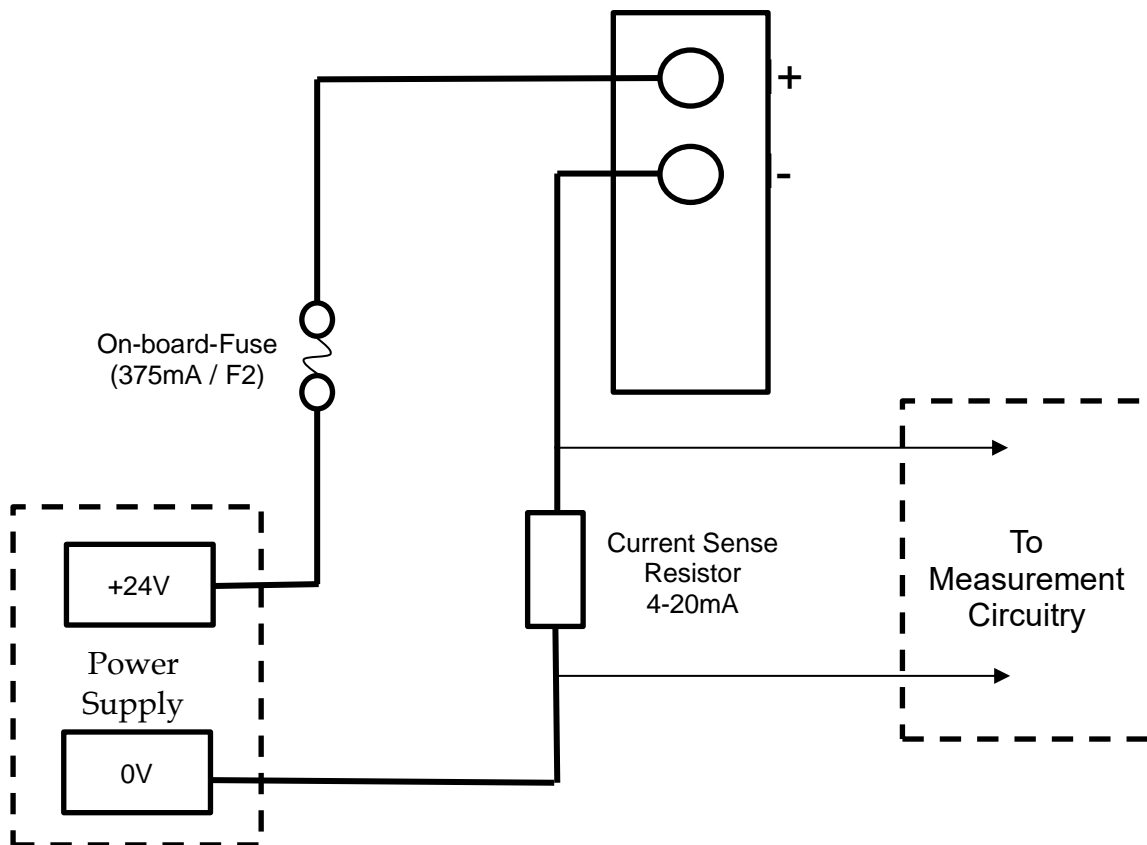
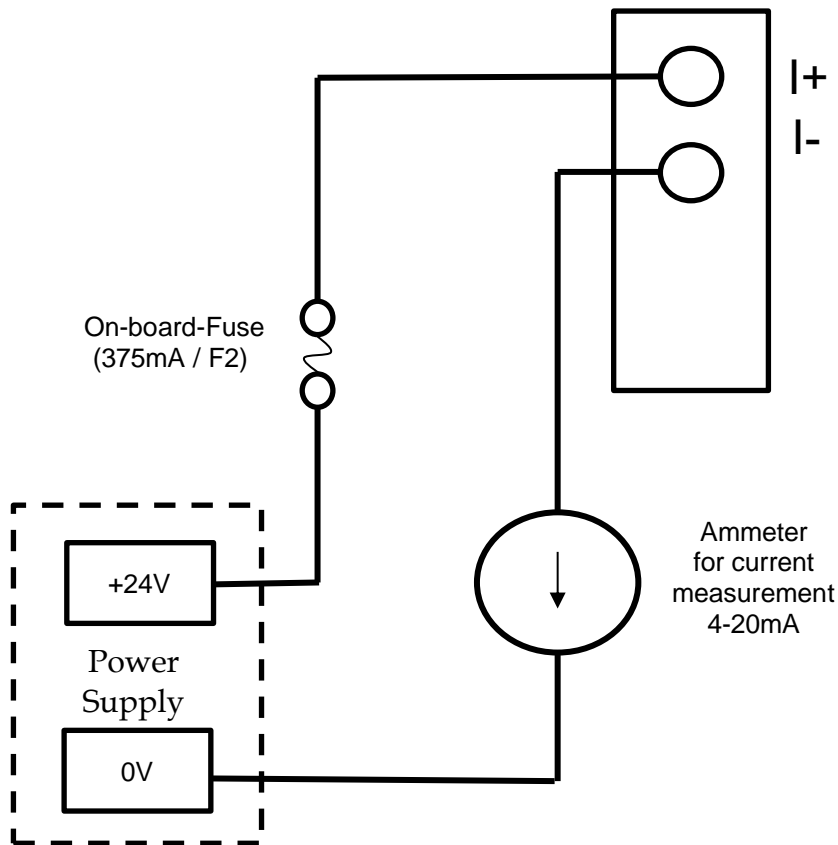

Removal and Installation of the Detection Module

To Remove the Detection Module

Switch off or remove the power to the benzene monitor.

WARNING:

1. Ensure the electrical power is switched off or disconnected.
2. Do not open when an explosive atmosphere might be present.

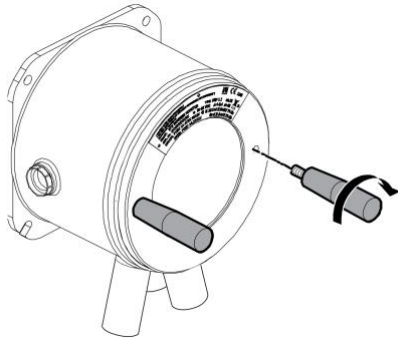

Insert the threaded Cover Removal Tools into the holes in the benzene monitor front cover.

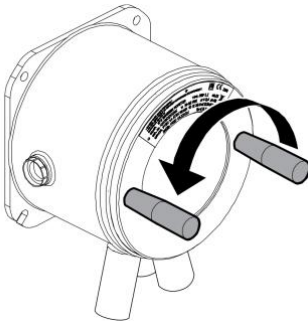

Turn counter-clockwise to unscrew the front cover.

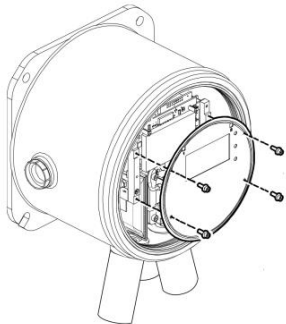

Use a 2mm allen-key to remove the four faceplate screws.
Remove the faceplate.

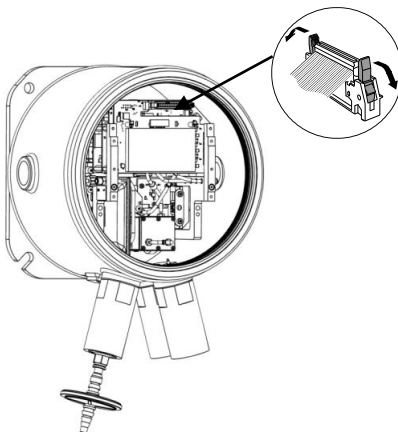

Press the 'wings' down to release the ribbon cable at the top of the Detection Module.

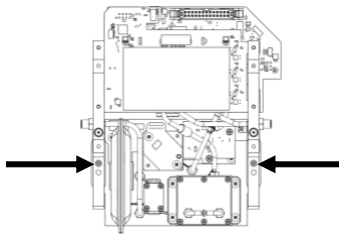

Two captive, hex-socket screws hold the Detection Module in the Housing Module, as shown.

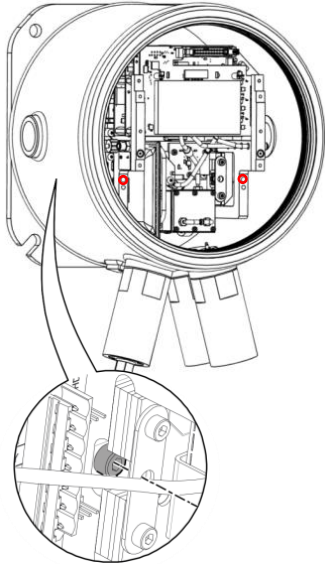

Two holes in the front of the Detection Module give access to the screws.

Use a 3mm allen-key to reach the screws directly behind the holes. Red circle indicates entry,

Turn each screw counter-clockwise until it is completely loose.

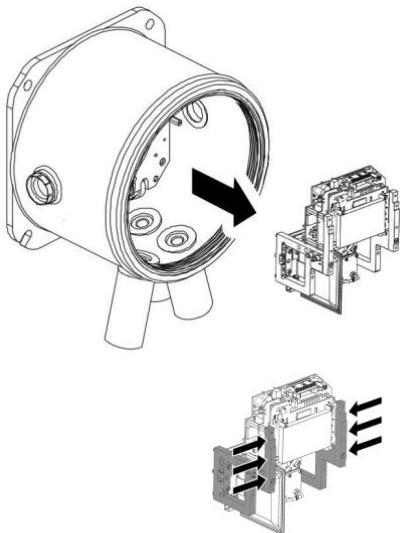

When the captive screws are completely loose, grip the sides of the frame of the Detection Module, as shown, to remove it from the Housing Module.

Be careful not to cause damage the PCBs.

Be careful to remove it only far enough to disconnect the Luer connectors of the 3 pneumatic tubes.

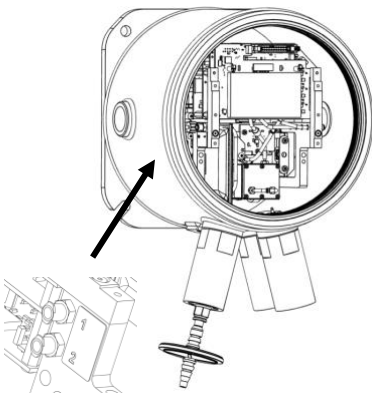

Ensure the pneumatic tubes are properly identified for later connection to the correct connectors.

Disconnect the tubes only from the Detection Module, not from the Housing Module. The tubes must remain connected at all times to the barbs on the interior face of the flame-arrestors.

For complete removal of the Detection Module: a half-turn, counter-clockwise, of the Luer connectors will remove the pneumatic tubes:

- two on the left
- one on the right.

You can now remove the Detection Module completely.

To Install the Detection Module

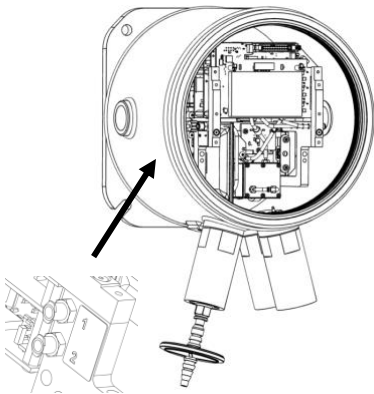

Check the identification of the pneumatic tubes and connectors.

Connect the tubes to the connectors: a half-turn, clockwise, of the Luer connectors will secure the pneumatic tubes:

- two on the left
- one on the right.

Port 3 remains open.

Ensure the tubes have no twists or kinks.

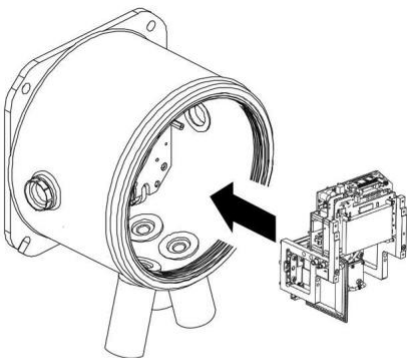

Hold the ribbon cable out of your way while you insert the Detection Module.

There are locating pins to ensure correct positioning of the Detection Module on the base-plate.

Move the module from side to side until it locks into place.

Ensure the tubes have no twists or kinks.

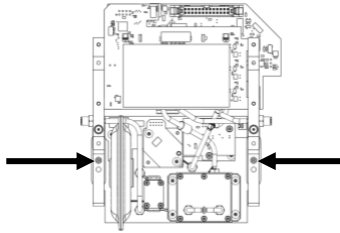

Use the allen-key to engage the captive screw at each side of the Detection Module.

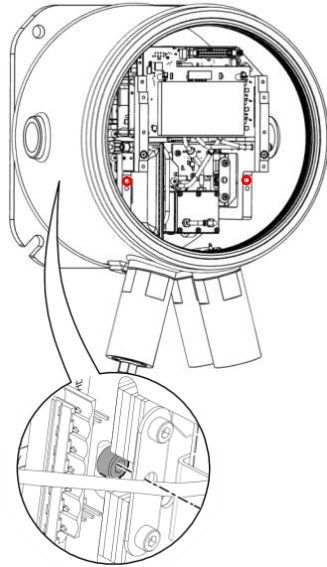

If the module is in its correct position, the screws will engage in the threads and turn freely.

If they do not engage the threads easily, check the position of the Detection Module.

Move the module from side to side until it locks into place.

Tighten them hand-tight.

Check the Detection Module is held firmly.

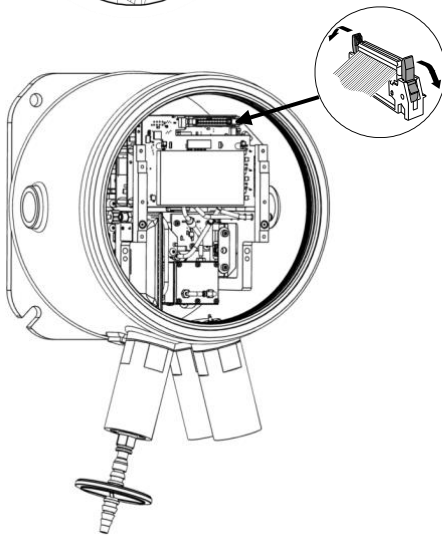

Attach the ribbon cable.

When you push it into its socket, it should clip in automatically.

Gently pull the cable to check it is securely connected.

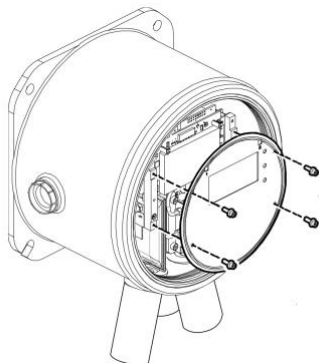

Use the four screws to attach the face plate. Tighten them firmly hand-tight.

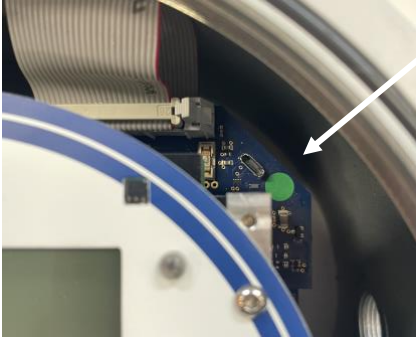

Connect a PC to the USB or RS485 connection and use benzene monitor PC software to set the date and time. Refer to [Settings](#).

The date and time is used to "Date-stamp" all data files and calibration history.

Without external power, benzene monitor can only store the current date and time for a maximum of 12 hours.

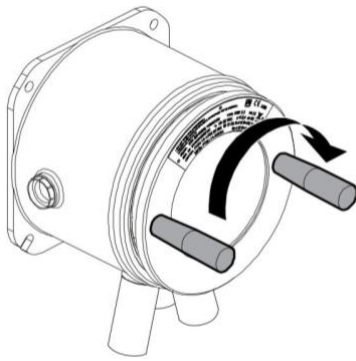

Install the front cover. Turn it clock-wise until it is hand-tight.

CAUTION: Be careful to ensure the front cover engages easily with the screw thread. If there is resistance, remove it, examine it, and try again. Do not use force. Force can cause damage to the threads.

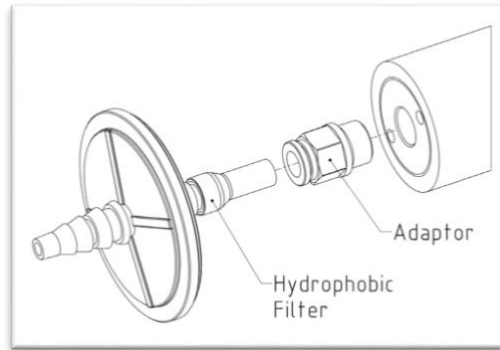
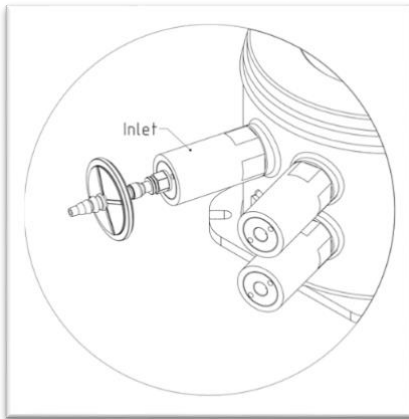

Ensure the external hydrophobic filter and any exhaust or inlet probe lines are connected.

Switch on or connect the power supply.

Do an after-installation test. Refer to

After-Installation Test.

Operating the benzene monitor

Switches and Display

The benzene monitor front face has:

- An LCD display,
- two switches, magnetically operated,
- three LEDs.



All three LEDs work together and display the same colour.

- | | |
|-------------|----------------------------------------------------------------------------------------------------------|
| LEDs Green | Benzene monitor is operating correctly. |
| LEDs Yellow | Benzene monitor has an operational fault.
An alert signal and the name of the fault is on the screen. |
| LEDs Red | The measured level of benzene is above the alarm threshold. |

Power on

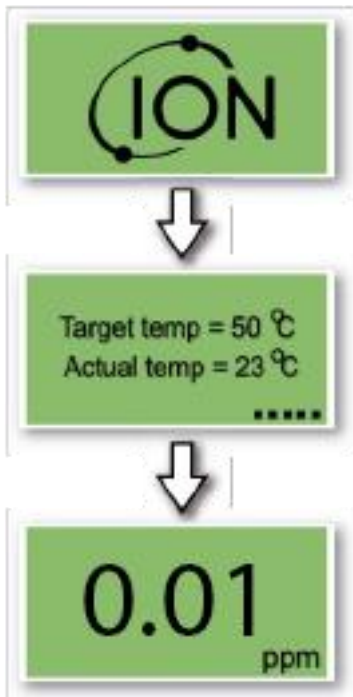

When power is turned on, the benzene monitor displays the 'Ion Science' logo followed by the firmware version.

The benzene monitor then starts to heat the AirSep filter. Normal operation cannot start until it reaches the target temperature. This will usually take a few minutes.

Normal operation starts when it is stable at the target temperature. The benzene monitor then displays the ambient benzene level in parts per million (ppm). This updates once per minute.

Main screens and main menu

The actuation magnet supplied with the benzene monitor operates the magnetic switches through the front cover.

On the main operation screen:

- Select Switch 2 to toggle between the current reading and the calculated STEL (Short-Term Exposure Limit) over the previous 15 minutes.
- Select Switch 1 to go to the main menu.

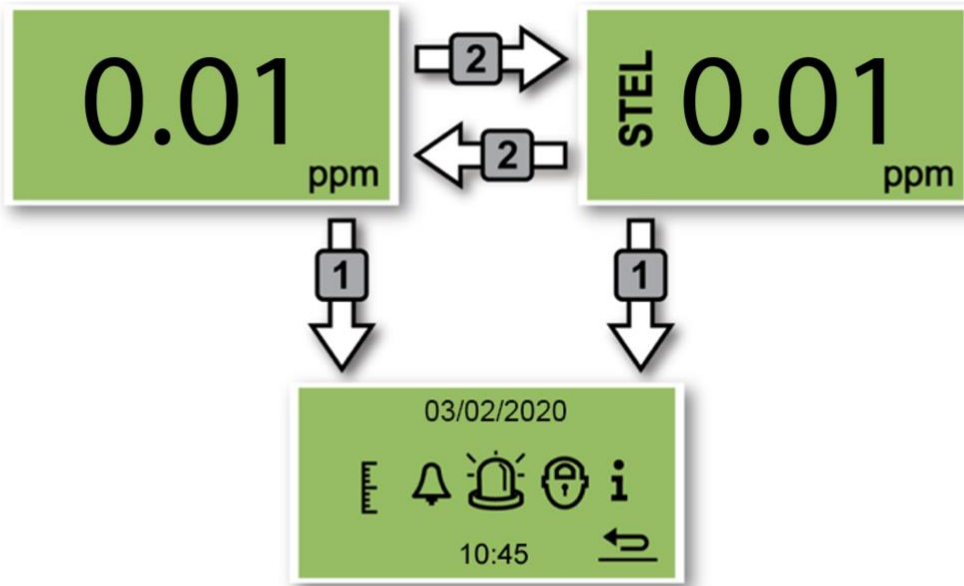

Menu Icons

	ICON ready to select or toggle		Return to previous screen		Information
	Calibration		Alarm Test		4-20mA comms system
	Alarm		Alarm 1		Alarm 2
	Lock		Unlock		Benzene monitor Display
	Relay		Relay 1		Relay 2

Navigation

The actuation magnet supplied with the benzene monitor operates the magnetic switches through the front cover.

- Use Switch 1 to move to the next icon or value (options).
- Use Switch 2 to select an option or toggle between values.

The icon or value ready for selection is shown by an underline

Select the arrow to return the previous screens.

Benzene Calibration

Select the Calibration icon to go the calibration menu.

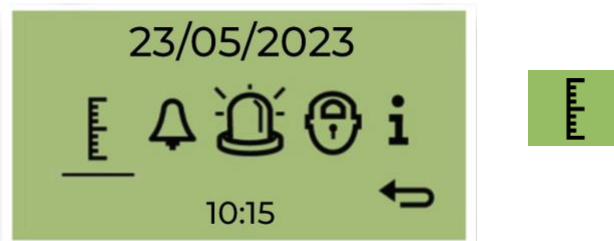

For accuracy over the full range; ION Science recommend a bottle of 5ppm benzene. The software allows you to use any benzene concentration from 0.1 to 20.0ppm, if your application has different requirements.

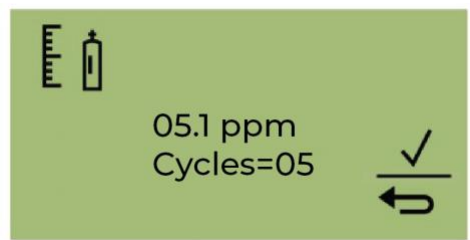

Move the cursor to the ppm value. Use Switch 2 to cycle through the values to the benzene concentration of the bottle.

Move the cursor to the Cycles value. This allows you to change the number of 1-minute cycles the benzene monitor will do during calibration. Ion recommends that 5 cycles will provide an accurate calibration.

Select ✓ to start the confirm.



Attach the bottle before you start calibration. This ensures that benzene is flowing through the benzene monitor system before the start of the calibration.

Connect the bottle to the hydrophobic filter on the inlet of the flame-arrestor of the benzene monitor. Use a fixed-flow regulator that delivers more than 300ml/min. A demand-flow regulator will not perform correctly and can damage the benzene monitor. You will need to use a flood-leak (tee-piece) with a carbon filter on the leak. This is to prevent gas pressure irregularities from affecting the instrument.

Select ✓ to start the calibration process.

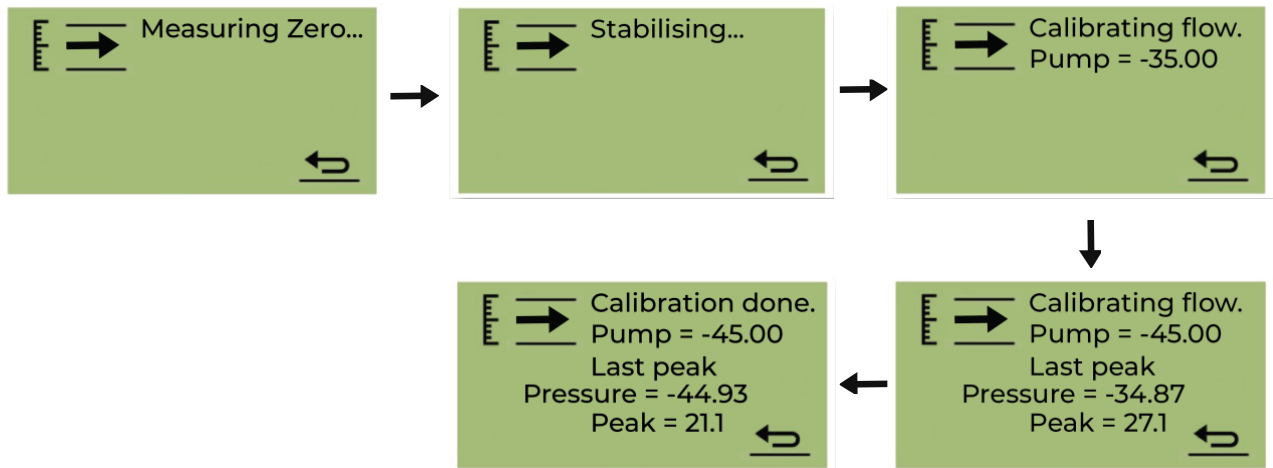

Benzene monitor analyses the gas for a default time of 10 minutes. You can select the return arrow icon to stop the calibration process at any time. Calibration is done and successful. Select ✓ to save and return to the main menu. The new calibration will replace the previous calibration in the Detector Module. Select return to not save and return to main menu. Do a Bump Test to check the calibration. Refer to **Bump Test**.

Removal of the Memory Card

You can remove the memory card from the benzene monitor. You can then connect the card to a PC and use benzene monitor PC software to download and read the data.

While the Memory card is removed, the benzene monitor cannot log data.



For safe removal of the memory card, use the magnet to actuate switch 1 for 5 seconds.



The benzene monitor goes into safe mode. The Memory card removal screen shows when it is safe to remove the card.

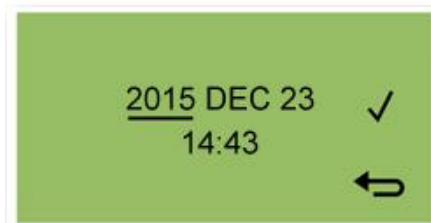

When you remove the memory card, the arrows change direction to show that you must insert a card. Use the magnet to actuate switch 1 for 5 seconds to exit menu.

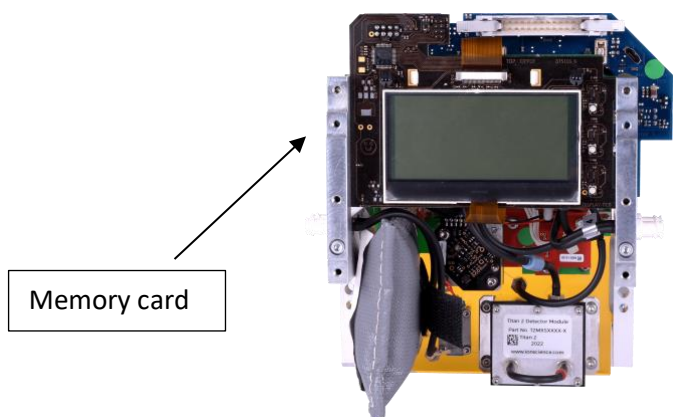

IMPORTANT: Fit the memory card before the service module is fitted into the EXD enclosure. The memory card is push to connect and push to release so may be pressed inadvertently during servicing. Always check the memory card is inserted correctly after servicing.

Password Lock

The password lock lets you:

- Prevent access to the calibration: so that selecting the calibration icon on the main menu will not access calibration menu.
- Prevent viewing of measured benzene levels: so the STEL and LIVE benzene displays will be blank.

You will use a 4-digit pin to turn the lock function on or off.

Benzene monitor is supplied with a default PIN of 0000 and with calibration and viewing unlocked.



Select the lock icon on the main menu.

Lock the Calibration



On the "Lock Select" menu, select the calibration icon to lock or unlock the calibration screens.

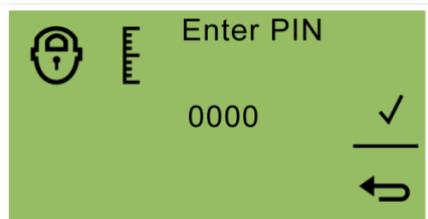

On the "Enter PIN" screen, use Switch 2 to cycle through the values to set the first digit. Use Switch 1 to move to the next digit.

The factory-set default is 0000.

When all the digits are set, Select ✓ to go to the "Lock/Unlock" screen.



On the "Lock/Unlock" screen use Switch 2 to toggle between locking and unlocking the calibration.

Then select return to go to the "Lock Select" screen.

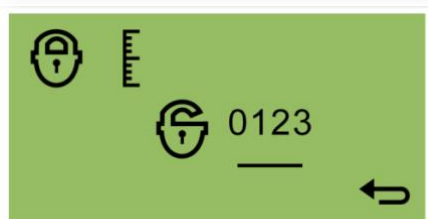

To change the PIN, use Switch 1 to navigate to the PIN number icon then use Switch 2 to select it.

This will take you to the "Enter new PIN" screen.

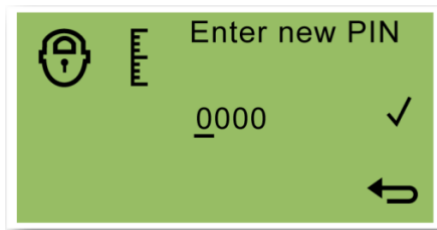

On the "Enter new PIN" screen, use Switch 2 to cycle through the values to set the first digit. Use Switch 1 to move to the next digit.

When all the digits are set:

- Select ✓ to save the PIN and return to the "Lock screen"
- Select  to return to the lock screen without saving the PIN.

Lock the STEL and LIVE Displays



On the "Lock Select" menu, select the benzene monitor Display icon to prevent or allow viewing the STEL and LIVE values on the screen.

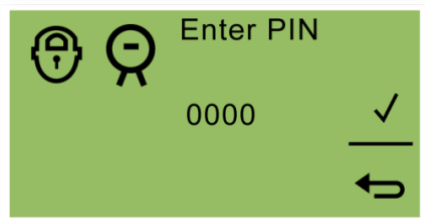

On the "Enter PIN" screen, use Switch 2 to cycle through the values to set the first digit. Use Switch 1 to move to the next digit.

The factory-set default is 0000.

When all the digits are set, Select ✓ to go to the "Lock/Unlock" screen.



On the "Lock/Unlock" screen use Switch 2 to toggle between locking and unlocking the display.

Then select return to go to the "Lock Select" screen.

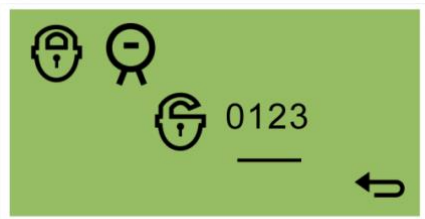

To change the PIN, use Switch 1 to navigate to the PIN number icon then use Switch 2 to select it.

This will take you to the "Enter new PIN" screen.



On the "Enter new PIN" screen, use Switch 2 to cycle through the values to set the first digit. Use Switch 1 to move to the next digit.

When all the digits are set:

- Select ✓ to save the PIN and return to the "Lock screen"

Select  to return to the lock screen without saving the PIN.

Alarms and Relays

The alarms and relays are individually programmable to the settings required by the site policy. You can choose either alarm to energize either relay. The default settings would be. When the benzene monitor is not powered the default state of relay 1 is N/C, the default state of relay 2 is N/O.

- Alarm 1: 5.0ppm live
- Alarm 2: 0.5ppm STEL
- Relay 1: Alarm 1, N/O
- Relay 2: Alarm 2, N/O

Both relays can be programed to be Normally Open or Normally Closed.

Alarm or Relay Selection

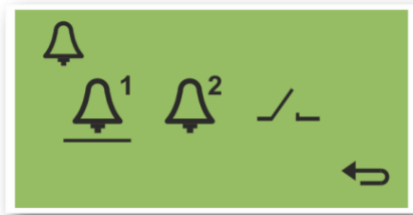

Select:

- Alarm 1
- Alarm 2
- Relays

That takes you to the configuration screen for that item.

Alarm Configuration

The configuration procedure for Alarm 1 is shown. Alarm 2 is the same.



Toggle between:

- STEL
- LIVE

Move the cursor to the value.

Use Switch 2 to cycle through the values to the target value.

STEL:

Alarm starts when the STEL concentration is equal to or greater than target value.

LIVE:

Alarm starts when the current concentration is equal to or greater than target value.

-- ppm:

The target value concentration.

Relay Configuration

This menu lets you set which relay each alarm operates and whether the relay is normally open (NO) or normally closed (NC).

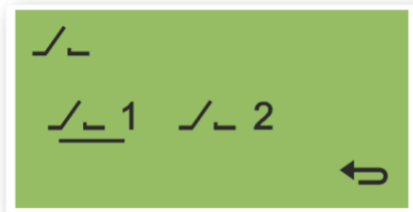

Select Relay 1 or Relay 2.

That takes you to the configuration screen for that relay.

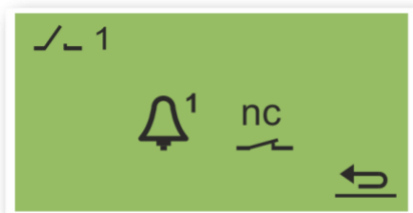

Select the Alarm Icon.

Toggle between:

- Alarm 1
- Alarm 2
- Instrument FAULT.

Select the contacts Icon.

Toggle between NO and NC.

Relays and 4-20mA Test

Do a test of the relay and the 4-20mA systems to check for correct installation and function.

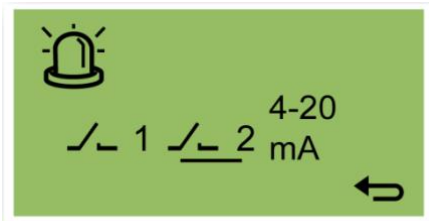

Select Relay 1, Relay 2 or 4-20mA.

That takes you to the test screen for the relay or 4-20mA system.

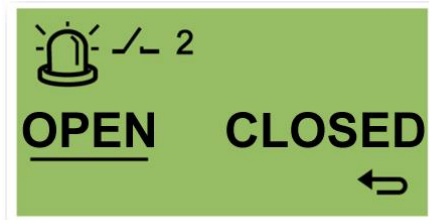

On the Relay test screen, toggle between OPEN and CLOSED to manually operate the relay.

When you return  to the previous screen, the system returns to normal operation.

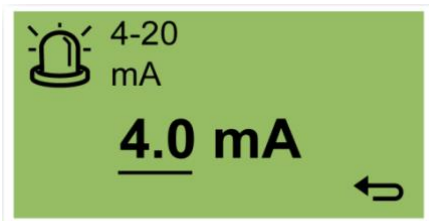

On the 4-20mA test screen, use switch 2 to cycle through the output values. The 4-20mA output changes to the value displayed.

When you return  to the previous screen, the system returns to normal operation.

Information Pages

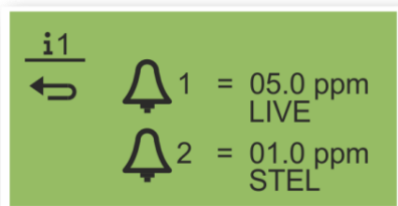

Information Page 1

Alarm 1 configuration settings
Alarm 2 configuration settings

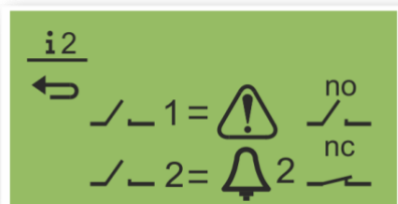

Information Page 2

Relay 1 configuration settings
Relay 2 configuration settings

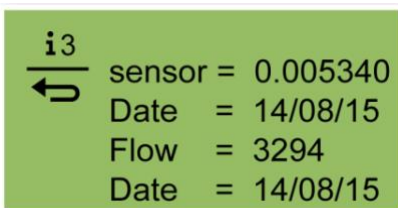

Information Page 3

Sensor calibration value
Sensor Calibration date
Flow Calibration value
Flow calibration date

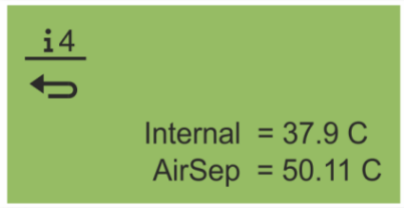

Information Page 4

Benzene monitor internal temperature
AirSep temperature

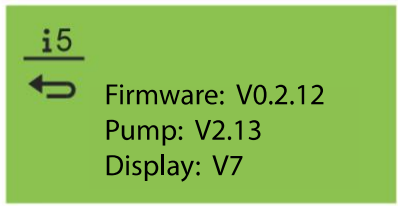

Information Page 5

Firmware version number
Pump Driver Board Version Number

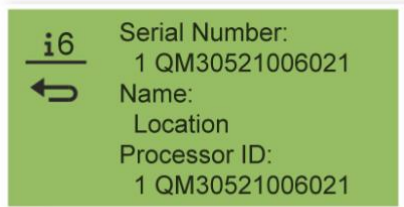

Information Page 6

Instrument serial number
User settable location
Processor serial number

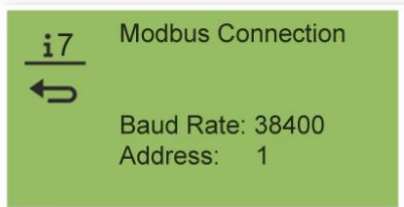

Information Page 7

Baud rate
Modbus address

Fault Indications



If there is a fault:

- The three LEDs show Yellow
- The main screen changes to a - Warning Screen and gives the name of the fault at the bottom. Use the Fault Name to find information from the [Fault Diagnostics](#) section of this manual.

Alarm Indications



If the benzene level exceeds one of the two target concentration values selected during Alarm Configuration:

- The three LEDs on the front panel show red.
- An alarm symbol and the alarm number, is displayed in the top right of the screen.
- If a relay is associated with the alarm, it is energized.
- Benzene detection continues.
- The alarm is only raised if the current cycle is above the alarm thresholds.

Service Period Reminder



Benzene monitor counts continuous days of operation. When it reaches 180 days:

- The screen changes to "Service Required"
- The three LEDs on the front panel show yellow.

Only a Service Centre can reset it.

Benzene monitor PC Software

The benzene monitor PC software lets you connect to the Detection Module to:

- Calibrate the module
- View and download the detection and fault histories stored in the module
- Set the operating thresholds of the alarms and relays
- Adjust the time and date settings in the module clock
- Give the module an identification appropriate to its installation
- Upgrade the operating firmware on the module.

Minimum requirements

Benzene monitor PC Software works on PCs or laptops with operating systems:

- Windows Vista
- Windows 7
- Windows 8 / 8.1
- Windows 10
- Windows 11

Connect the benzene monitor to the PC

1. Install the Detector Module into the Test Housing Module.
2. Connect the USB or RS485 output to the PC.
3. Connect or switch on the power supply.
4. Start benzene monitor PC.

Starting the Software

After installation, click on the benzene monitor PC icon  on the desktop to start the software.

Benzene monitor PC shows a start-up window while loading the software, then the Main Operation Window when ready for use.



Benzene monitor PC shows ten icons at the top of the window. Click on an icon to see the window you want.



Connection



Engineering



Settings



Fault Log



Data Download



Alarm and Relay Configuration



Upgrade



Data View



Calibration



Virtual Display

Data Connection

Click the  icon for the Connection window.

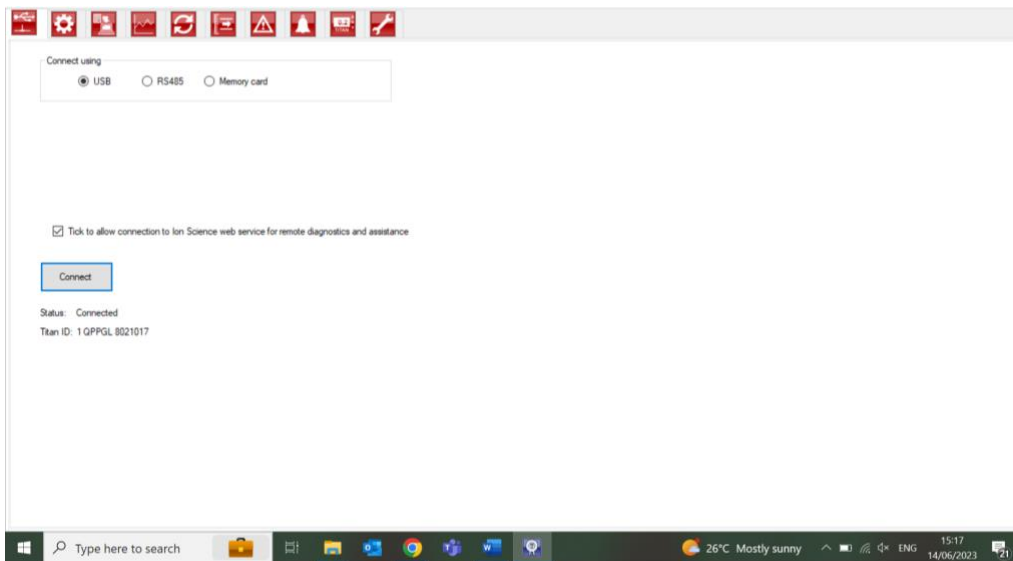

Click on the comms connection button for USB or RS485, to select the connection type.

- RS485 is normally used when the Test Housing Module is a permanent installation The default address of the benzene monitor is 10
- USB is normally used for a bench-top set-up or connect a PC/Laptop to a Detector Module in its normal, installed position.

Click on the "Connect" button to manually connect to the benzene monitor.

If connection is successful, it will show the status and ID of the benzene monitor.

Or you can remove the memory card from the benzene monitor (Refer to

Removal [of the Memory Card](#)) and insert it into the pc. Then select Memory Card and click Browse to find the card location. After connection, you can download and view the data on the card.

If the benzene monitor is connected via USB, and the PC is connected to the internet, you can tick the check-box to allow Ion Service Support to remotely connect to the benzene monitor to view factory level data and configuration values.

Settings



Click the  icon for the Settings window.

The software should automatically scan for data when started. The "Read from benzene monitor " button lets you manually scan for data, if necessary.

When the software has successfully connected to the benzene monitor, the serial number, instrument name and instrument date and time are displayed.

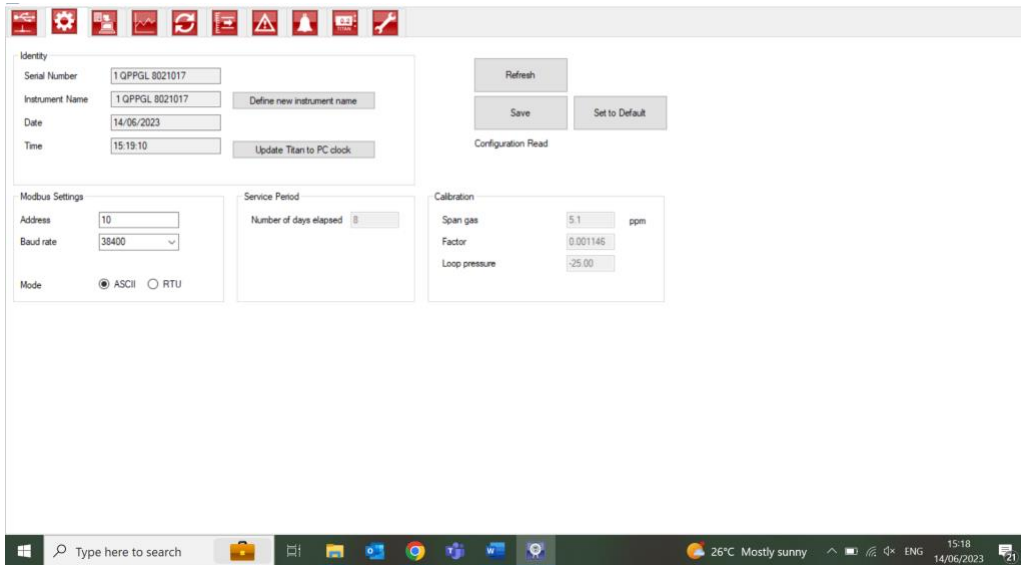

You can change the instrument name to something more meaningful (for example, 'Area 1 Monitor').

You can change the benzene monitor date and time to the same as the PC clock.

Modbus: There is three settings that be changed which include the address, baud rate and the option to change between ASCII and RTU.

Service period: Displayed in days since last service.

Calibration value: Test gas concentration, sensor calibration factor and flow calibration factor.

NOTE:

1. The benzene monitor internal clock is automatically set during calibration using benzene monitor PC. Without external power, benzene monitor can only store the current date and time for a maximum of 12 hours.

Data Download



Click on the  icon for the Data Download window.

When data is available to download, a list of the available dates is displayed under "File Date" on the left.

If necessary, click "Refresh" to scan the instrument for fresh data.

Click on the available dates to select the data you want.

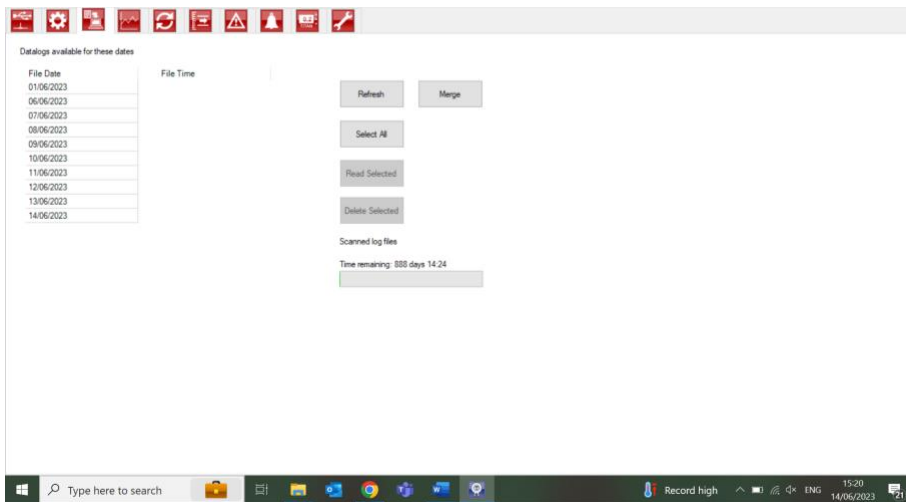

Use standard windows functions to select groups of dates, e.g.:

- For consecutive files click the first one, hold down the Shift Key [Shift] and click on the last file you want.
- For non-consecutive files, hold down the Control Key [Ctrl] and click on each file you want.

Or click the "Select All" button if you want all the files.

After selecting the files:

Click "Read Selected" to download the files to the PC

Click "Delete Selected" to delete the files.

The bar at the bottom of the screen indicates how much memory is used/unused in the benzene monitor.

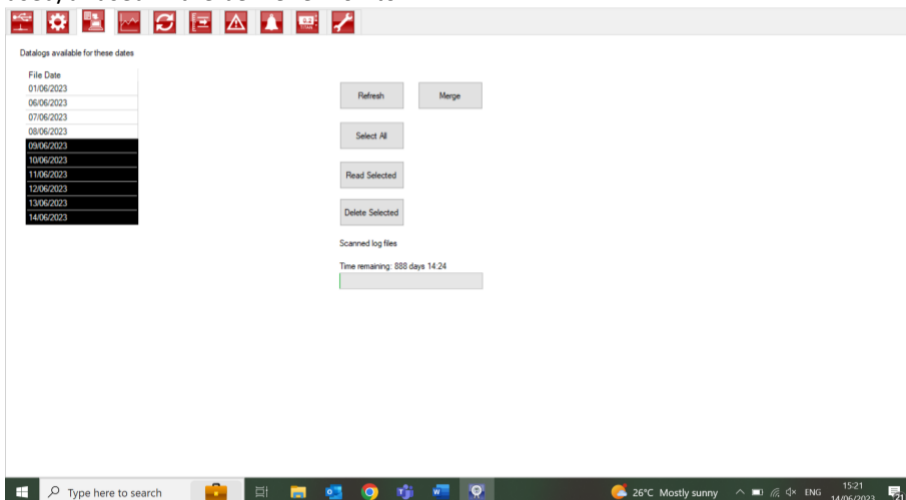

Data View



Click on the  icon for the Data Download window.

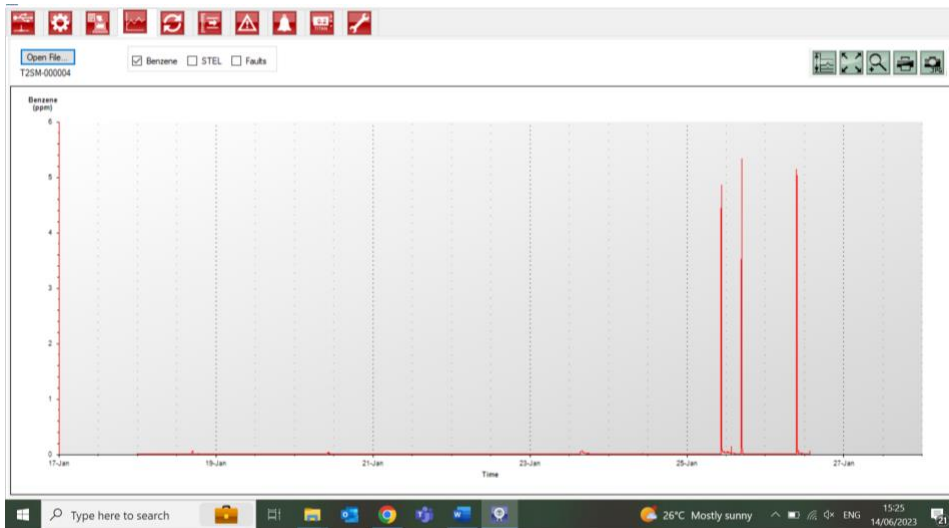

Data View allows you to view, print or save pictures of graphs of the data in files downloaded from benzene monitor using Data Download. You can change the presentation to how you want to see it.

Click the 'Open File' button and select a file from the list.

Benzene monitor PC shows the data as a graph, or graphs superimposed on each other using the same time-axis. Each data-set has its own, colour-coded, axis on the left. Fault groups (refer to

Benzene monitor PC Fault Groups) are shown in a bar-graph at the top of the screen.

The tick-boxes at the top let you choose which graphs you see.



Hold down the left mouse button to grab and drag the graph around the screen. Use the mouse wheel to zoom in and out.

There are 5 control buttons at the top right of the screen:



Scales – adjustment of data-axis scales.

Click on this to manually adjust the axis of each data-set.

In the pop-up window, click on the arrows, or type-in numbers to change the maximum and minimum values of the scale. Click the 'Auto Scale' button to revert to the default values.



Zoom to fit (Auto-scale).

Click this to reset the graph to make all data visible (Auto-scale).



Zoom.

Click this to zoom-in on an area of the graph. The cursor changes to a magnifying glass when over the graph. Hold down the left mouse button to draw a rectangle around the area you want to enlarge. Click the Zoom button again to leave zoom mode.



Print.

Click this to print the view you have on the screen.



Save as a Picture.

Click this to save the view you have on the screen, as a picture. You can save in jpg, emf, bmp, tif, png, or gif format.

Upgrade

Click on the  icon for the Upgrade window.

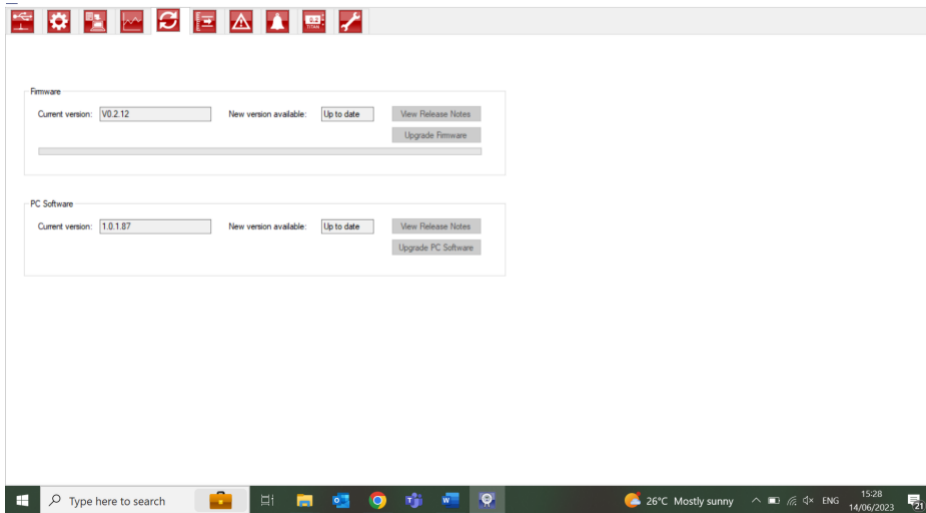

If the PC is connected to the internet benzene monitor PC will automatically detect if a new version of firmware or software is available.

If new firmware or software is available, you can view the release notes or do an upgrade.

Calibration



Click on the  icon for the Calibration window.

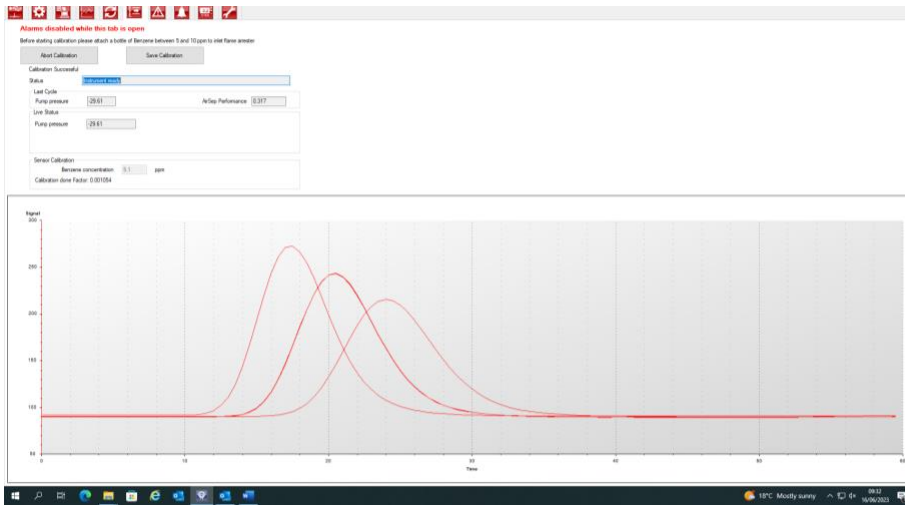

Attach a bottle between 0.1 ppm – 20 ppm Benzene to the inlet flame-arrestor before you start calibration. This ensures the benzene is flowing through the benzene monitor system before the start of the calibration.

Click the "Start Calibration" button. The text on the button will change to "Abort Calibration." You can click the button again to any time to stop the calibration and reset the screen to its original state.

"Last Cycle" shows the pump power and AirSep Performance value for the previous cycle.

If the AirSep Performance value is larger than the specified configuration value then the calibration will fail.

"Live Status" shows the applied pump power and measured differential pressure of the current cycle. If the pump cannot run between the limits of 'Minimum Pump Power' and 'Maximum Pump Power' then the calibration will fail.

The "Save Calibration" button is not active until the calibration is complete and successful. The new calibrated flow will not replace the old setting in the Detector Module until you click the button. The text "Calibration Saved" will then appear next to the button.

The Status, Pump power and Differential pressure stay on the screen until you start a new calibration.

Do a Bump Test to check the calibration. Refer to [Bump Test](#).

During the procedure the "Status" message shows:

"Instrument ready"	When there is a Detector Module connected to benzene monitor PC.
"Stabilising flow"	When the pump power has been adjusted and the software is waiting for stable flow conditions.
"Running measurement cycle"	When the software is doing a measurement cycle.
"Calibration successful"	When the calibration is complete and successful.
"Calibration failed: AirSep fault"	When the calibration diagnoses a failure of the AirSep.
"Calibration failed: pump power high"	When calibration diagnoses that the pump power required for a working flow is too high.

“Calibration failed: pump power low”

When calibration diagnoses that the pump power required for a working flow is too low

Recorded Faults



Click on the icon for the Recorded Faults window.

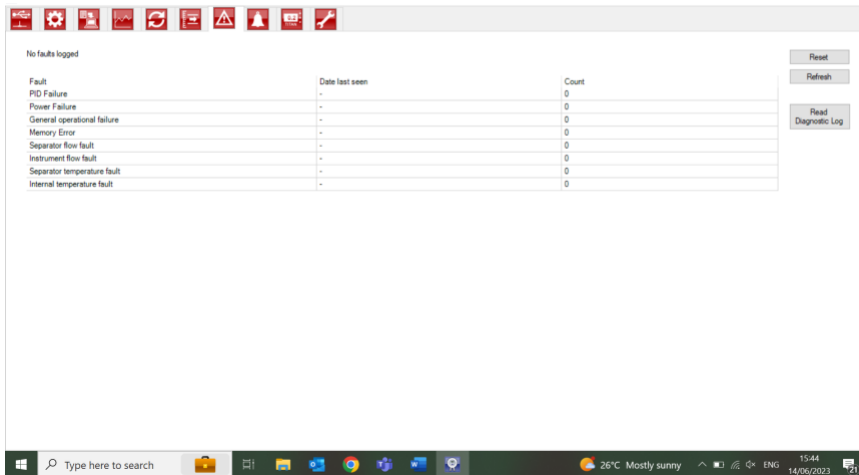

This screen shows the last date a fault occurred and how many times it has occurred.

Click "Refresh" to scan for the latest fault data.

Click "Reset" to clear all the fault reports to zero.

For more details of the fault conditions, refer to the

Fault Diagnostics section of this manual.

Pressing the 'Read Diagnostic Log' button opens the following screen. The diagnostic file and comments can be sent to Ion Science or to an e-mail of the user's choice.

Email Ion Science Ltd.

Your email address (to allow us to reply - optional)

Instrument number

Additional files to send

Subject

Please add any comments you wish to send

I confirm that I am sending data to Ion Science Ltd and am happy for Ion Science Ltd to use that data

Alarm Set

Click on the icon for the Alarm Set window.

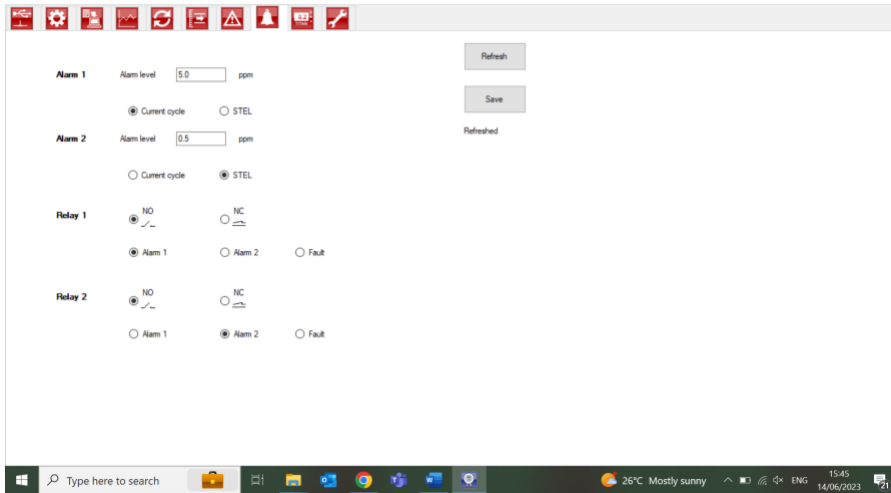

You can set each alarm to operate when the STEL or Current level of Benzene reaches a set value in ppm.

- In the window, type the value to trigger the alarm.
- Click on the radio button to choose STEL or Current value as the trigger.

You can select which alarm or fault will operate each relay and whether it is normally open NO or normally closed NC.

For each relay select between:

- Alarm 1
- Alarm 2
- Instrument FAULT.

Select the contacts as NO or NC.

Click "Refresh" to reset the screen to the values in the benzene monitor.

Click "Save" to set the benzene monitor to the values on the screen.

Virtual Screen

Click on the icon for the Virtual Screen window.

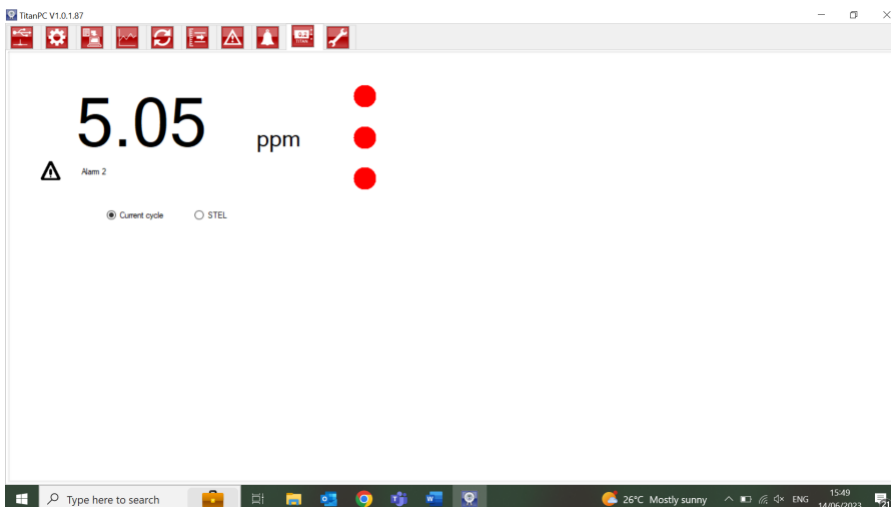

This tab displays in real time what is displayed on the benzene monitor screen. A radio button allows the user to switch between the current cycle reading and the calculated STEL.

Engineering



Click on the spanner icon to access the engineer section.

In this section, you can access information on the instruments control, signal process and flow.

Control

Control includes the following information: ByPass Flow, Clock, Heater, Identity, Sampling, Temperature.

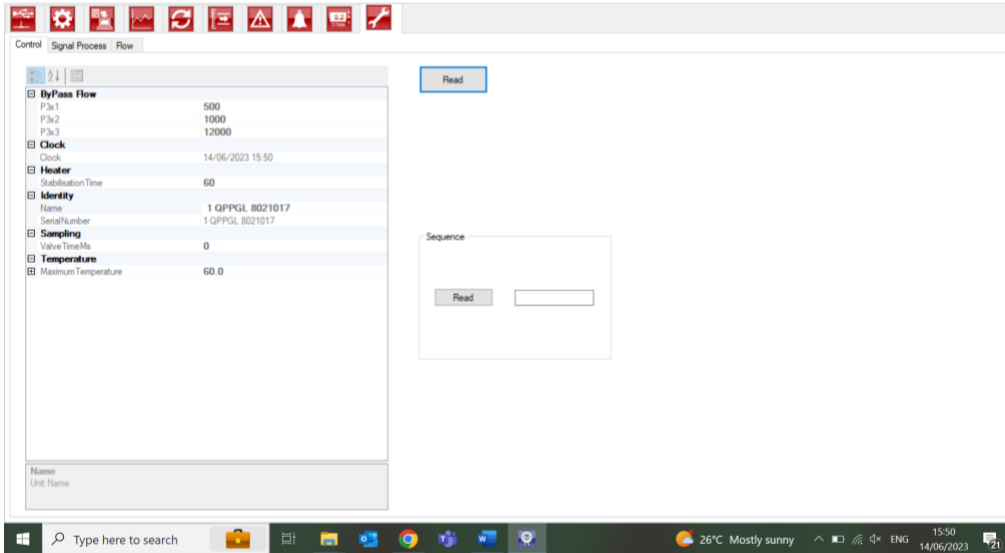

Signal Process

Signal process includes the following information: Calibration, Extrapolation, Peak, Slope, Trough.

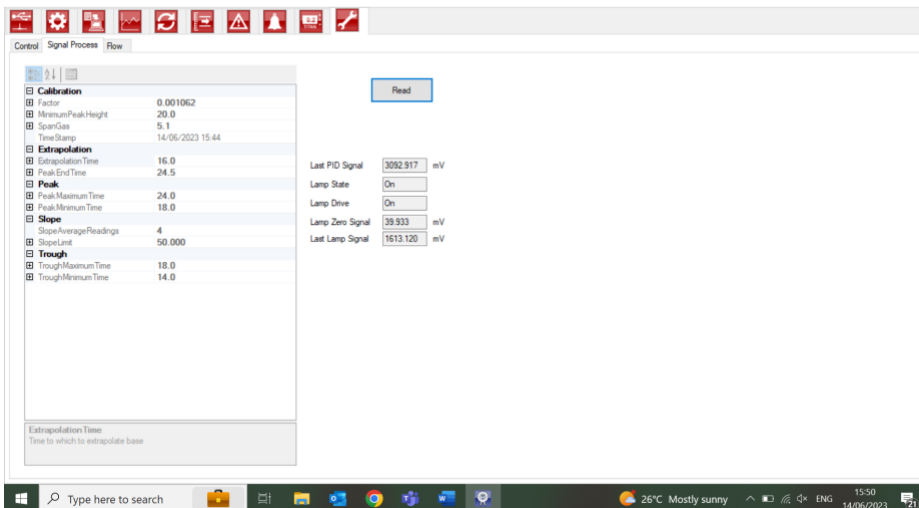

Flow

Flow includes information on the following: Outer loop pump, valve control, inner loop, outer loop and flow control.

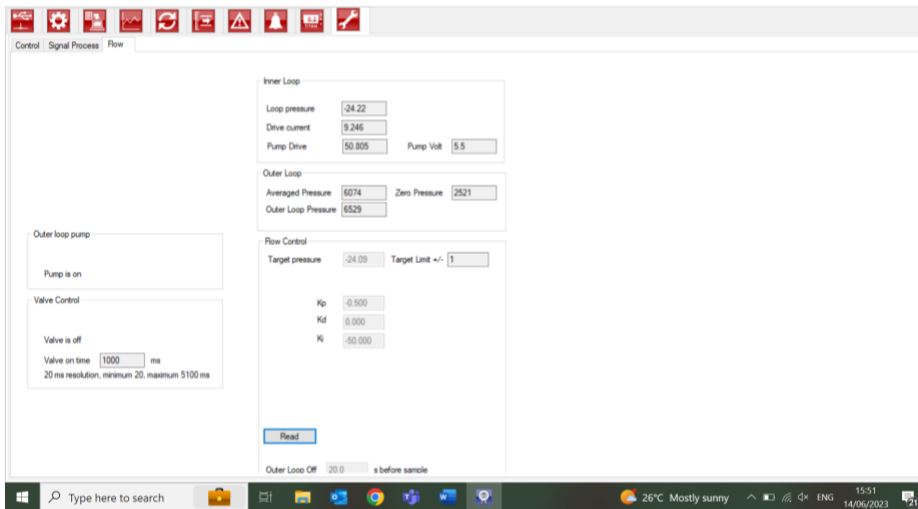

Bump Test

A "Bump Test" is not a calibration. The test verifies that the benzene monitor is accurately measuring benzene at a known concentration supplied from a bottle.

Use of the Test

Ion Science Ltd. recommend you do a Bump Test:

- After initial installation.
- After replacement of a Detector Module.
- Once per week. Or at a regular period specified by the installation site policy.
- If the benzene monitor is exposed to a high gas concentration.
- If the benzene monitor receives a large physical shock.
- If the benzene monitor is exposed to silicone poisons.

Test Procedure

Ion Science Ltd recommended you use a bottle of 5ppm benzene equipped with a fixed-flow regulator that delivers more than 300mL/min with a flood-leak. A demand-flow regulator will not perform correctly and can damage the benzene monitor.

You can use any concentration from 0.1 to 20.0 ppm benzene, if your application has different requirements.

Connect the bottle to the hydrophobic filter on the inlet flame-arrestor. Allow 3 minutes for the reading on the benzene monitor display to stabilise.

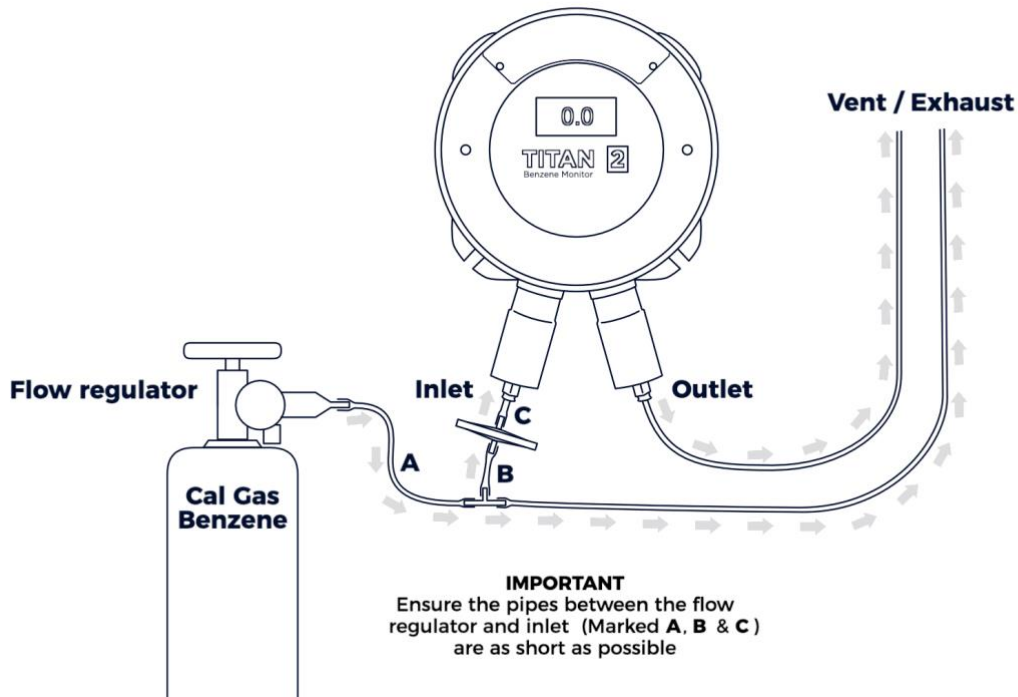

If the benzene monitor does not display the gas concentration given by the bottle, calibrate the benzene monitor to give the correct readings. Refer to:

Calibration

Benzene monitor PC Calibration

Manually energize the relays and 4-20mA system to verify correct connection of the systems. Refer to [Relays and 4-20mA Test](#).

Fault and Alarm indications



If there is a fault, the main screen changes to a Warning Screen and gives the name of the fault under the warning icon.

Use the Fault Name in the table below to find the possible conditions causing the fault.

Fault Conditions

The benzene monitor is equipped with a number of diagnostics to ensure instrument faults are detected and communicated. The table gives a fuller description of each fault and list some possible causes and corrective actions you can try.

If the fault continues, or is repeated, contact your Service Centre.

Abbreviations:

CTO = Continues to Operate. (benzene monitor continues to operate but results might not be correct.)

Norm = Normal Operation

Fault Name and Description	Possible Causes and Corrective Actions	4-20mA signal	LED colour	CTO
Service Required:				
The benzene monitor requires its 6-month service check.	Benzene monitor has recorded 180 days of continuous operation without a service. This can only be reset by an Ion Science Service Centre.		Yellow	Yes
Temp error:				
Ambient temperature too high. or AirSep temperature out of limits.	Ambient temp >50, Try cooling or shading the benzene monitor to prevent overheating. AirSep temp <45 or >80 Or failed to reach temp within 180 mins, Possible thermocouple fault. Contact the Service Centre.	2.000	Yellow	Yes
Temp fault:				
Instrument temperature too high for extended period.	Ambient T >50 for 1 hour Try cooling or shading the benzene monitor to prevent overheating.	2.125	Yellow	Yes
Sensor flow low:				

AirSep flow too low.	Check for kinks or pinches in the tube between port 3 and the inlet flame-arrester.	2.250	Yellow	Yes
Sensor flow high:		2.375	Yellow	Yes
AirSep flow too high.	Check that AirSep filter is pushed in firmly and internal tube connections are not loose. Recalibrate the flow.			
Outlet Blocked:		2.500	Yellow	Yes
Reduced flow through the outlet flame-arrester.	P3 values not correct. Check for kinks or pinches in the tube between port 4 and the outlet flame-arrester.			
Tube off:		2.625	Yellow	Yes
Increased flow through the inlet flame-arrester.	P3 values not correct. Check for leaks between the external (Hydrophobic) filter and the inlet flame-arrester. Check for leaks between the external (Hydrophobic) filter and the extended probe line, if installed. Check for any disconnected tubes within the Detector Module.			
Inlet Blocked:		2.750	Yellow	Yes
Reduced flow through the inlet flame-arrester.	P3 values not correct. Check the external (Hydrophobic) filter is not blocked. Check the extended probe line, if installed, is not blocked or kinked. Check the inlet flame-arrester for damage or blockage. Check for kinks or pinches in the tubes within the Detector Module.			
Lamp Out:				

No signal from PID Light sensor.	PID Lamp not illuminated. Sensor failure. During benzene monitor start-up, wait at least 5 cycles for the lamp to illuminate.	2.875	Yellow	Yes
Memory full:		Norm	Red	Yes
Not enough memory space to store history.	Memory full. Use benzene monitor PC to download or delete History Record Files.			
PID ADC Fail:		3.000	Yellow	Yes
Communication failure	Internal hardware fault. Remove the Detector Module to check that the black wiring loom is connected and not damaged.			
Step overrun:		Norm	Red	Yes
Internal hardware fault	Program code step took more than 0.5s to execute. Contact the Service Centre.			
Step error:		Norm	Red	Yes
Software fault.	Invalid sequence step. Contact the Service Centre.			
Watchdog:		3.125	Red	Yes
Software fault.	Software fault. Contact the Service Centre.			
Pump fault:		3.250	Yellow	Yes
Failed communication with pump board.	Internal hardware fault. Contact the Service Centre.			
Pump power fail:		3.375	Yellow	No
Pump power fault.	Pump board power failure. Contact the Service Centre.			

Benzene monitor PC Fault Groups

To reduce file size and memory usage, fault records are grouped together in the files stored on the benzene monitor and downloaded to the benzene monitor PC.

Benzene monitor PC Group Name	Faults in the Group
PID failure	Lamp out, PID ADC fail
Power failure	Pump power fail
General Operational failure	Step overrun, Watchdog, Pump fault, Step error
Memory full	Memory full
Separator flow fault	Sensor flow high, Sensor flow low
Instrument flow fault	Outlet blocked, Inlet blocked, Tube off
Separator temperature fault	Temp error
Internal Temperature fault	Temp fault

ION Science Contact Details

ION Science Ltd – UK/Head Office

Tel: +44 (0)1763 208 503

Web: www.ionscience.com | Email: info@ionscience.com

ISM ION Science Messtechnik – Germany Office

Tel: +49 (0) 2104 1448-0

Web: <https://www.ism-d.de/en/> | Email: sales@ism-d.de

ION Science India - India Office

Tel: +914048536129

Web: www.ionscience.com/in | Email: kschhari@ionscience.com

ION Science Inc – USA Office

Tel: +1 877 864 7710

Web: <https://ionscience.com/usa/> | Email: info@ionscienceusa.com

ION Science Italy - Italy Office

Tel: +39 051 0561850

Web: www.ionscience.com/it | Email: info@ionscience.it

ION Science China - China Office

Tel: +86 21 52545988

Web: www.ionscience.com/cn | Email: info@ionscience.cn

Manual Log

Manual version	Amendment	Issue date	Instrument firmware	PC software
1.1	Page 8 – Software / Firmware versions updated (SW – V1.0.0.88, FW – V0.2.13) Page 9 - Recommended service and maintenance schedule for the benzene monitor.	18.06.24	n/a	n/a